

MOUNTING AND OPERATING INSTRUCTIONS



EB 2640 EN

Translation of original instructions



Type 2371-11 Pressure Reducing Valve
Manual set point adjustment

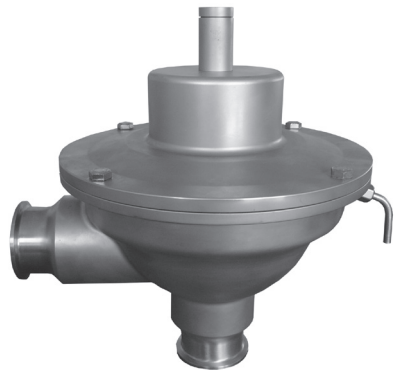

Type 2371-10 Pressure Reducing Valve
Pneumatic set point adjustment

Type 2371-10 Pressure Regulator · Pneumatic set point adjustment **Type 2371-11 Pressure Regulator · Manual set point adjustment**

Series 2371 Pressure Reducing Valve for the Food and Pharmaceutical Industries

Edition May 2024



Note on these mounting and operating instructions

These mounting and operating instructions assist you in mounting and operating the device safely. The instructions are binding for handling SAMSON devices.

- For the safe and proper use of these instructions, read them carefully and keep them for later reference.
- If you have any questions about these instructions, contact SAMSON's After-sales Service (aftersaleservice@samsongroup.com).



The mounting and operating instructions for the devices are included in the scope of delivery. The latest documentation is available on our website at www.samsongroup.com > **Downloads** > **Documentation**.

Definition of signal words

DANGER

Hazardous situations which, if not avoided, will result in death or serious injury

WARNING

Hazardous situations which, if not avoided, could result in death or serious injury

NOTICE

Property damage message or malfunction

Note

Additional information

Tip

Recommended action

| | | |
|-----------|---|-----------|
| 1 | General safety instructions..... | 4 |
| 2 | Process medium and scope of application..... | 5 |
| 2.1 | Transportation and storage | 5 |
| 3 | Design and principle of operation | 6 |
| 4 | Installation | 10 |
| 4.1 | Mounting orientation | 10 |
| 4.2 | Shut-off valve and pressure gauge..... | 10 |
| 4.3 | Safety valve | 11 |
| 4.4 | Leakage line connection | 11 |
| 5 | Operation | 12 |
| 5.1 | Start-up..... | 12 |
| 5.2 | Adjusting the set point | 12 |
| 5.2.1 | Set point · Type 2371-11 | 12 |
| 5.2.2 | Set point · Type 2371-10..... | 14 |
| 5.3 | Operation | 14 |
| 5.4 | Decommissioning..... | 14 |
| 6 | Cleaning and maintenance | 14 |
| 6.1 | Cleaning | 15 |
| 6.2 | Maintenance · Replacing parts..... | 19 |
| 6.3 | Replacing the plug | 19 |
| 6.4 | Replacing the diaphragm unit | 21 |
| 6.5 | Replacing the two diaphragms | 22 |
| 6.5.1 | Replacing the set point springs | 24 |
| 7 | After-sales service | 24 |
| 8 | Nameplate..... | 25 |
| 9 | Technical data | 26 |
| 10 | Dimensions | 28 |



1 General safety instructions

- The regulator is to be mounted, started up or serviced by fully trained and qualified personnel only; the accepted industry codes and practices are to be observed. Make sure employees or third parties are not exposed to any danger.
- All safety instructions and warnings given in these mounting and operating instructions, particularly those concerning installation, start-up, and maintenance, must be strictly observed.
- According to these mounting and operating instructions, trained personnel refers to individuals who are able to judge the work they are assigned to and recognize possible dangers due to their specialized training, their knowledge and experience as well as their knowledge of the applicable standards.
- To ensure appropriate use, only use the regulator in applications where the operating pressure and temperatures do not exceed the specifications used for sizing the regulator at the ordering stage.
- The manufacturer does not assume any responsibility for damage caused by external forces or any other external factors.
- Any hazards that could be caused in the regulator by the process medium, operating pressure or by moving parts are to be prevented by taking appropriate precautions.
- Proper transport, storage, installation, operation, and maintenance are assumed.
- If solenoid valves are installed downstream of the regulator when the regulator is used to control liquids, pressure peaks may occur when the solenoid valves close quickly. The installation of solenoid valves downstream of the regulator is not permitted when the regulator is used to control liquids.

i Note

According to the ignition risk assessment performed in accordance with Clause 5.2 of ISO 80079-36, the non-electrical actuators and valves do not have their own potential ignition source even in the rare incident of an operating fault. As a result, they do not fall within the scope of Directive 2014/34/EU. For connection to the equipotential bonding system, observe the requirements specified in Clause 6.4 of EN 60079-14 (VDE 0165-1).

2 Process medium and scope of application

Pressure regulators for the food and pharmaceutical industries for liquids and gases in the temperature range from 0 to 160 °C/32 to 320 °F · K_{VS} 0.63 to 16/ C_v 0.75 to 20 · Nominal size DN 15 to 50/NPS ½ to 2.

For controlling the output pressure p_2 to the adjusted set point. The valve closes when the downstream pressure rises.

⚠ WARNING

The Type 2371-10/-11 Regulators are designed as safety valves. Exceeding the maximum pressure (10 bar/150 psi) of the regulator may cause it to burst. If necessary, a suitable overpressure protection must be installed on site in the plant section.

i Note

The Type 2371-10 and Type 2371-11 Regulators are shut-off devices that do not guarantee absolute tight shut-off. As a result, they may have leakage when closed (leakage class according to IEC 60534-4 or ANSI/FCI 70-2, see Chapter 9 on page 26). As a result, the output pressure p_2 can rise to the same level as the input pressure p_1 in a plant which does not have its own consumption.

2.1 Transportation and storage

The regulators must be carefully handled, transported and stored. During storage and transportation before installation: Protect the regulators against adverse influences, such as dirt, moisture or temperatures outside the operating temperature range.

3 Design and principle of operation

The Type 2371-10 and Type 2371-11 Pressure Reducing Valves consist mainly of a single-seated angle valve with operating diaphragm and actuator housing.

The set point of the Type 2371-10 is adjusted pneumatically by an external air supply, e.g. compressed air.

The set point of Type 2371-11 is adjusted manually by tensioning the set point spring.

The medium flows through the valve body (1) in the direction indicated by the arrow. The position of the plug (3) determines the flow rate across the area released between plug and valve seat (2). The valve closes when the downstream pressure p_2 rises above the adjusted set point. The resulting output pressure p_2 depends on the flow rate.

Any medium escaping from the test connection (11) indicates that the operating diaphragm (4) may be leaking or the diaphragm has ruptured. The test connection of Type 2371-10 is connected to a flexible pipe elbow to discharge any medium escaping (leakage line connection).

Type 2371-11 · Version with manual set point adjustment (see also Chapter 5.2 on page 12)

In the idle state, the valve is kept open by the set point springs (7). The valve closes when the output pressure p_2 acting on the diaphragm (4) and the resulting force exceed the force of the springs.

The set point is adjusted by an Allen key (8 mm), which is inserted through the adjustment opening (6.1) on top of the housing onto the set point screw (6). The blanking plug must first be removed. If necessary, the set point screw can be secured by the locking screw (12) in the upper plug section to prevent the set point screw from loosening due to vibrations, causing the set point to change.

The washer (15) serves as a bottom end stop to protect the diaphragm from overload and to prevent parts from falling apart inadvertently while the regulator is being dismantled.

Turning the set point screw clockwise causes the spring plate (7.1) to move upwards and increases the spring force and the set point. Turning the set point screw counterclockwise relieves the spring tension and reduces the set point.

Type 2371-10 · Version with pneumatic set point adjustment (see also Chapter 5.2 on page 12)

In the idle state, the valve is kept open by the set point pressure p_c (compressed air) applied as the control pressure.

When the force created by the output pressure p_2 acting on the diaphragm exceeds the force resulting from the set point pressure p_c , the plug (3) moves towards the seat (2), closing the passage. In this case, the ratio between p_1 and p_c is not necessarily 1:1.

As the output pressure p_2 drops, the resulting force reduces again. The valve is opened again when the pressure falls below the set point pressure p_c .

The two diaphragms (4.1) provide a certain amount of safety when one of the diaphragms ruptures and prevents the process medium and external pressure medium from

mixing. The screw (12) prevents parts from falling apart inadvertently while the regulator is being dismantled.

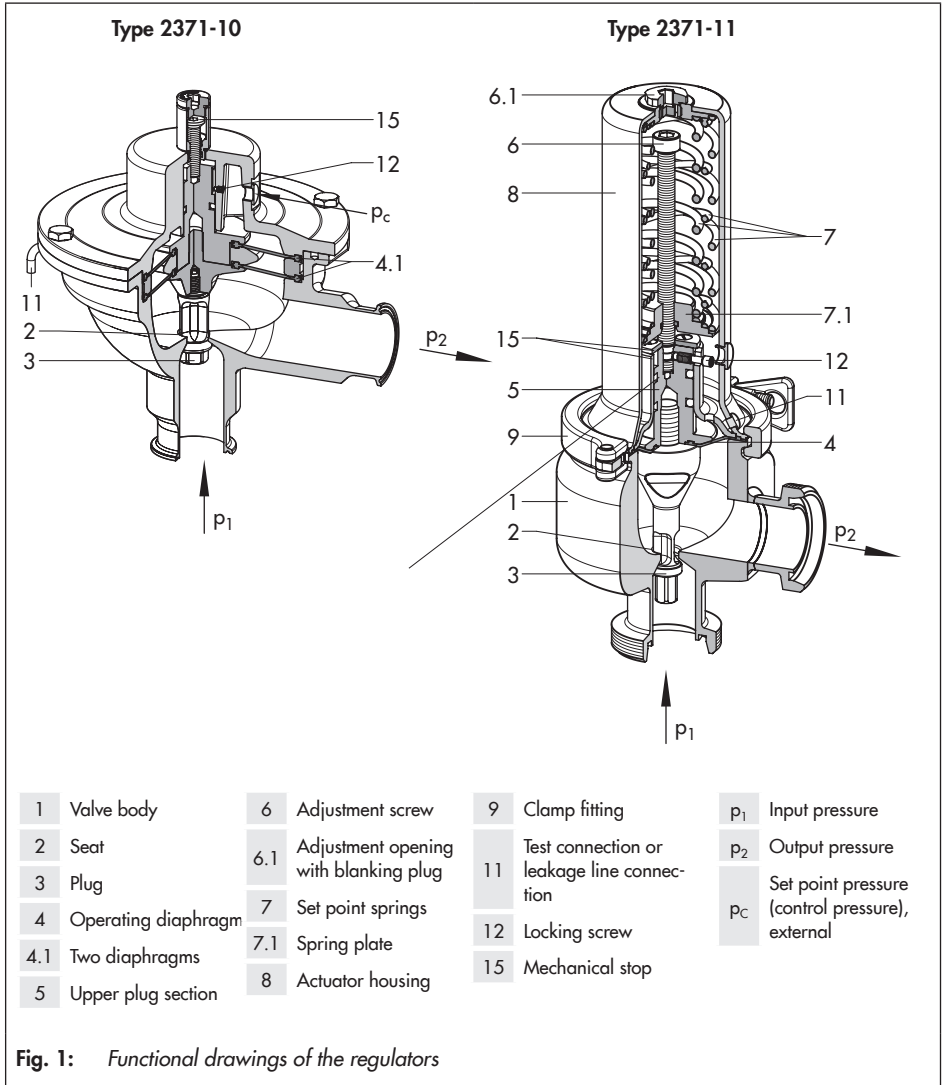

Design and principle of operation

Stem locking for CIP or SIP

See Chapter 6.1 on page 15.

The Type 2371-10 and Type 2371-11 Regulators can be fitted with a stem locking to keep the plug in the open position. In this version, the plug can be locked in the open position to allow the valve to be cleaned (CIP = Cleaning In Place or SIP = Sterilization In Place) while it is open.

The stem can be locked in place pneumatically by an additional pneumatic unit with compressed air connection (for Types 2371-10 and 2371-11) or manually using a special pin (for Type 2371-11 only).

The pneumatic and manual stem locking do not affect the control function of the valve, provided the stem locking is not engaged.

The pneumatic unit for the pneumatic stem locking is located on the top of the regulator. The unit can be mounted in any position since the axial fixture of the unit allows it to turn 360°.

The pin of the manual stem locking is screwed into the adjustment opening in place of the blanking plug.

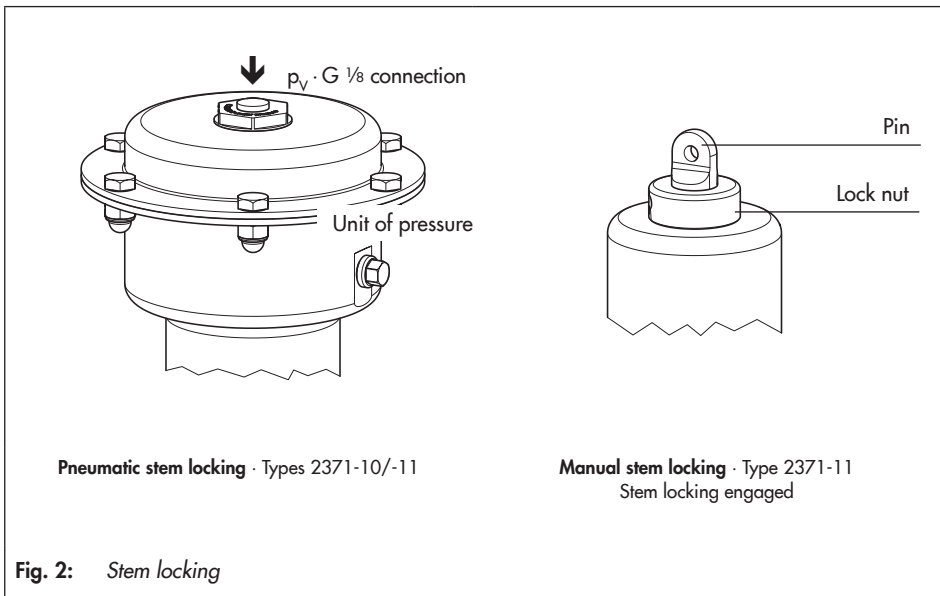

Pneumatic stem locking

Type 2371-10

To open the valve, apply a pressure p_V (= 1 bar) to the pneumatic unit. This causes the plug stem to move together with the plug out of the valve seat. A set point pressure p_C must not be applied to the regulator in this case.

To switch the valve back to its control function, remove the pressure p_V (= 1 bar).

Type 2371-11

To open the valve, apply a pressure p_V (= 6 bar) to the pneumatic unit. This causes the plug stem to move together with the plug out of the valve seat, opposing the spring force.

To switch the valve back to its control function, remove the pressure p_V (= 6 bar).

Manual stem locking

Type 2371-11 only

To lock the stem into place, screw the pin into the opening on top of the actuator housing in place of the blanking plug. The end of the pin comes to rest on the head of the set point screw. As the pin is screwed into the valve, it pushes the plug into the open position over the set point screw and upper plug section. A mechanical stop prevents it from being screwed in any further, protecting the diaphragm from overstretching or rupturing. Secure the position using the lock nut.

When the groove of the pin is completely concealed, the stem locking is active, whereas a visible groove means it is disengaged.

4 Installation

NOTICE

Damage due to pressure peaks.

If solenoid valves are installed downstream of the regulator when the regulator is used to control liquids, pressure peaks may occur when the solenoid valves close quickly. The installation of solenoid valves is not permitted when the regulator is used to control liquids.

NOTICE

Pay particular attention to correct hygiene and ensure that regulators for the food and pharmaceutical industries are kept absolutely clean.

The tools used must be free of solvents and grease. Only use a lubricant suitable for foodstuffs (order no. 8150-9002) for parts that must be lubricated.

Choose a place of installation that allows you to freely access the regulator even after the entire plant has been completed and allows unobstructed set point adjustment.

Before installing the regulator in the pipeline, clean the pipeline thoroughly to remove any foreign particles in the plant which could affect the regulator's proper functioning.

The plant must be designed and the pipelines installed in such a way that the regulator can be mounted and operated without any tension. If necessary, support the pipeline near the connections. Do not attach supports to the regulator itself.

Select a straight section of pipeline without any disturbances as the site of installation for the regulator (to ensure that the control function is not affected by the flow conditions).

4.1 Mounting orientation

The regulator has an angle-style valve body. The actuator housing must face upwards. As a result, the outlet must face to the side in the installed position.



- The direction of flow must match the direction indicated by the arrow on the body (inlet at the bottom and outlet at the side).

4.2 Shut-off valve and pressure gauge

Install a manually operated shut-off valve upstream and downstream of the regulator. This allows the plant to be depressurized, if required. In addition, it serves to relieve the operating diaphragm of pressure when the plant is not operated for extended periods.

A pressure gauge downstream of the regulator allows the set point (to control the output pressure p_2) to be monitored.

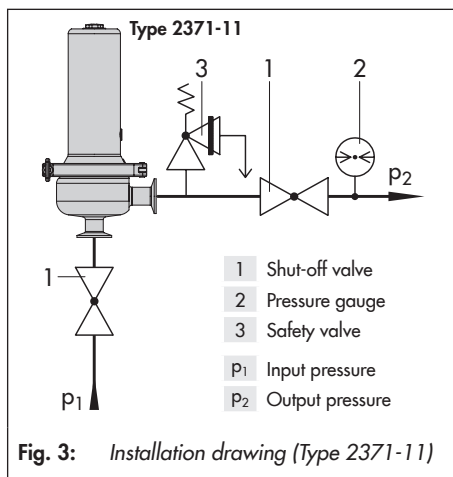

Fig. 3: Installation drawing (Type 2371-11)

4.3 Safety valve

The Type 2371-10 and Type 2371-11 Pressure Reducing Valves are shut-off devices that do not guarantee absolute tight shut-off. When closed, these regulators can have a leakage rate (see Chapter 9 on page 26).

As a result, the output pressure p_2 can rise to the same level as the input pressure p_1 in a plant which does not have its own consumption.

⚠ WARNING

The pressure in the entire system must not exceed the maximum permissible pressure. Corresponding safety equipment (e.g. safety valve) must be installed downstream of the regulator. Ensure that the pressure reducing valve itself cannot exceed the specified maximum pressure of 10 bar/150 psi.

The permissible temperature and pressure limits are specified on the regulator.

4.4 Leakage line connection

A leakage line can be connected to the regulator when toxic or dangerous media are used. In the event of a defective diaphragm (e.g. diaphragm rupture), any process medium that escapes can be fed through a pipe to a safe location.

Adapt the pipe diameter to the connection at the regulator.

5 Operation

5.1 Start-up

Do not start up the regulator until all parts have been mounted.

Fill the plant slowly with the process medium. Avoid pressure surges. Open the shut-off valves first on the upstream pressure side. Afterwards, open all the valves on the consumer side (downstream of the regulator).



Tip

For optimal control, the required pressure set point must be within the top end of the setting range.

5.2 Adjusting the set point

The set point must be adjusted on starting up the plant running under normal operating conditions.

The pressure gauge located on the downstream (output) pressure side allows the adjusted set point to be monitored.

- The set point adjustment in Type 2371-10 is pneumatic ¹⁾.
- The set point of Type 2371-11 is adjusted manually by tensioning the set point spring.

¹⁾ External supply air (e.g. compressed air, $p_{\max} = 8 \text{ bar}/115 \text{ psi}$) required

5.2.1 Set point · Type 2371-11

Manual set point adjustment · See Fig. 1 on page 7.

The set point is adjusted for the lowest output pressure in the delivered state. The locking screw (12) is **not** tightened.

NOTICE

The set point screw screwed in too far.

The regulator is blocked and the medium flow through it is restricted. Pressure regulation is no longer possible.

Only screw the set point screw up to the point where the spring tension can still be felt.

How to proceed:

1. Remove the stopper. Use an Allen key (3 mm) to undo the locking screw (12) if it is tightened (two turns counterclockwise).
2. Use an Allen key (8 mm) to remove the blanking plug (6.1).
3. Place the key through the opening to reach the set point screw (6).
4. Turn the set point screw (to tension the set point spring) to adjust the set point:
 - Turn clockwise ☺: Increases the pressure set point (the output pressure rises).
 - Turn counterclockwise ☹: Reduces the pressure set point (the output pressure drops).

Monitor the downstream pressure at a pressure gauge (see Fig. 3 on page 11).

The valve closes when the output pressure p_2 exceeds the pressure adjusted set point.

5. Retighten the locking screw (12) to prevent the set point screw (6) from being turned.
 - Reinsert the stopper.

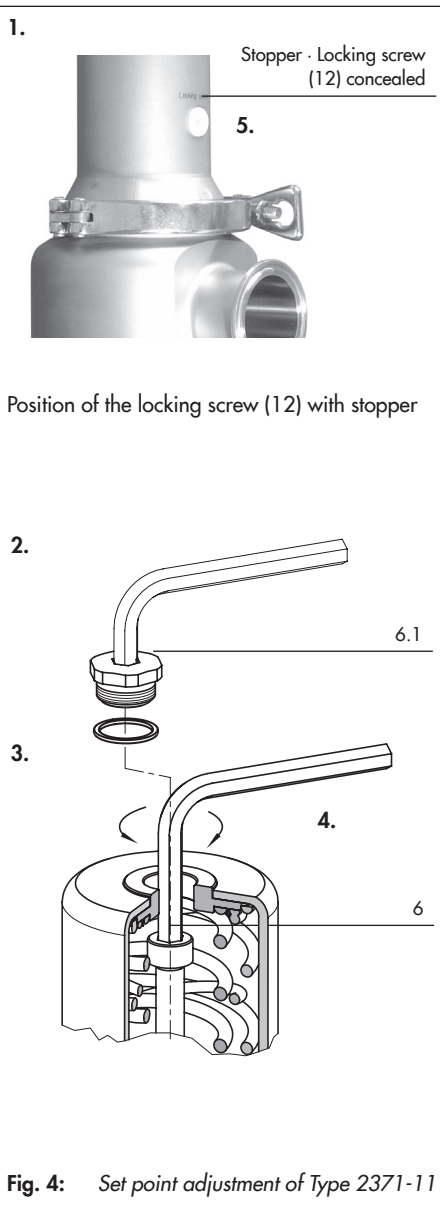

5.2.2 Set point · Type 2371-10

Pneumatic set point adjustment · See Fig. 1 on page 7.

How to proceed:

1. Connect the external set point pressure line at the G ¼ connection. Max. pressure $p_C = 8$ bar.
2. Adjust the set point pressure p_C to obtain and keep the required pressure constant.

Monitor the downstream pressure at a pressure gauge (see Fig. 3 on page 11).

The valve closes when the output pressure p_2 exceeds the pressure adjusted set point.

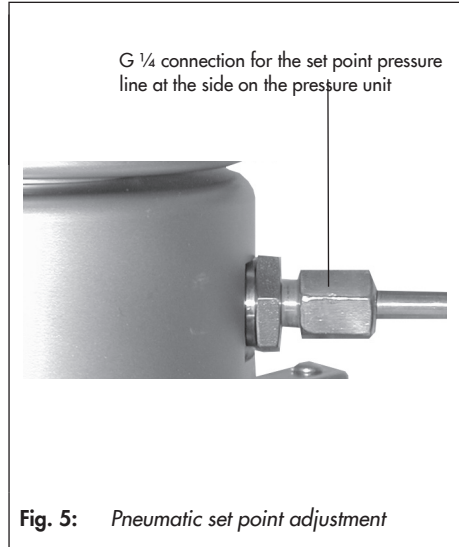

Fig. 5: Pneumatic set point adjustment

5.3 Operation

A correctly sized Type 2371-10/-11 Pressure Reducing Valve works automatically within its control range.

We recommend after every start-up to check that the regulator functions properly and to adapt it to new operating conditions, if necessary.

5.4 Decommissioning

Close the shut-off valve upstream of the valve and then close the shut-off valve downstream of the valve.

i Note

Before performing any work on the regulator, make sure the relevant plant section has been depressurized and, depending on the process medium, drained as well.

6 Cleaning and maintenance

The pressure reducing valves do not require much maintenance. Nevertheless, they are subject to natural wear, particularly at the seat, plug and operating diaphragm.

Depending on the operating conditions, check the regulator at regular intervals to avoid possible malfunctions.

⚠ WARNING

Be aware of the risks on performing work on pressurized or hot plant sections.

Hot process medium can escape uncontrolled on dismantling the regulator.

Risk of scalding.

Allow the regulator to cool down before depressurizing and draining it and remove it from the pipeline.

Check the seat and plug for wear. Check that the PTFE layer of the diaphragm (see Fig. 1, Fig. 12 and Fig. 13) is not damaged (e.g. cracks, milky coloring at the bends). This is necessary for compliance with EU 1935/2004.

If leakage still occurs and there is no visible signs of damage on the diaphragm, check the connection between the plug support and plug stem or the clamped connection between the valve body and bonnet (see Chapter 6.2 on page 19).

Tighten the connection to achieve a leak-proof joint.

6.1 Cleaning

To clean inside the regulator, the plug can be kept in the open position in the version with stem locking. This allows the entire plant with the regulator installed to be cleaned (CIP = Cleaning In Place or SIP = Sterilization In Place) while the regulator is open (see section "Stem locking for CIP or SIP" on page 8).

Stem locking: Pneumatic for Type 2371-10/-11 · Manual for Type 2371-11

The disengaged stem locking does not affect the regulator's control function.

Manual stem locking

Type 2371-11

See section "Stem locking for CIP or SIP" on page 8.

How to proceed:

1. Remove the blanking plug and screw the pin (13) of the stem locking with the lock nut (14) into the adjustment opening.
 - The end of the pin comes to rest on the head of the set point screw and keeps the plug in the open position. A mechanical stop prevents it from being screwed in any further, protecting the diaphragm from being overloaded.
2. Use the lock nut (14) to keep this position.
 - When the groove of the pin is completely concealed, the stem locking is active.
 - A visible groove means it is disengaged.
 - The control function of the valve is not affected when the stem locking is disengaged.

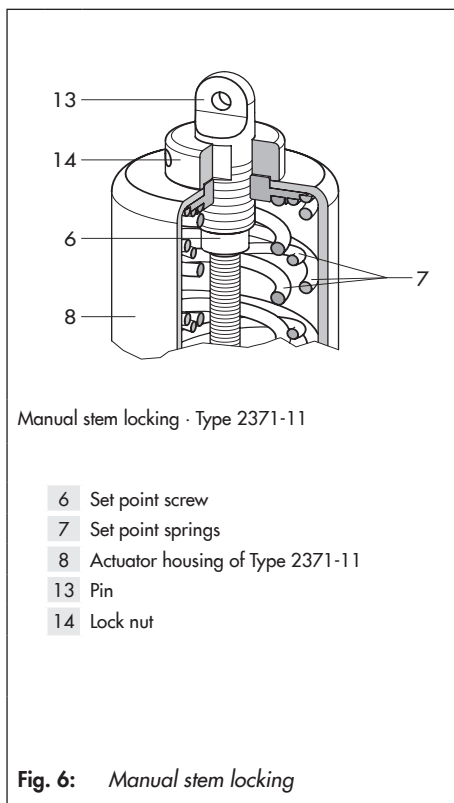

Pneumatic stem locking

Type 2371-10 and Type 2371-11

See section "Stem locking for CIP or SIP" on page 8.

Type 2371-11

The pressure $p_v = 6 \text{ bar}$ applied to the pneumatic unit opens the valve. This causes the plug stem to move together with the plug out of the valve seat and opens the valve.

How to proceed:

1. Connect the pressure line with min. 6 mm diameter to the G $\frac{1}{8}$ connection.
2. Apply a pressure $p_v = 6 \text{ bar}$ to the pneumatic unit. This causes the set point screw (6) to move and the plug to move out of the valve seat and opens the valve.
3. To switch the valve back to its control function, remove the pressure $p_v = 6 \text{ bar}$ to return the pressure back to atmospheric pressure.
4. The spring (16) pulls the actuating unit (18) back. The plug stem can move again for the control task.

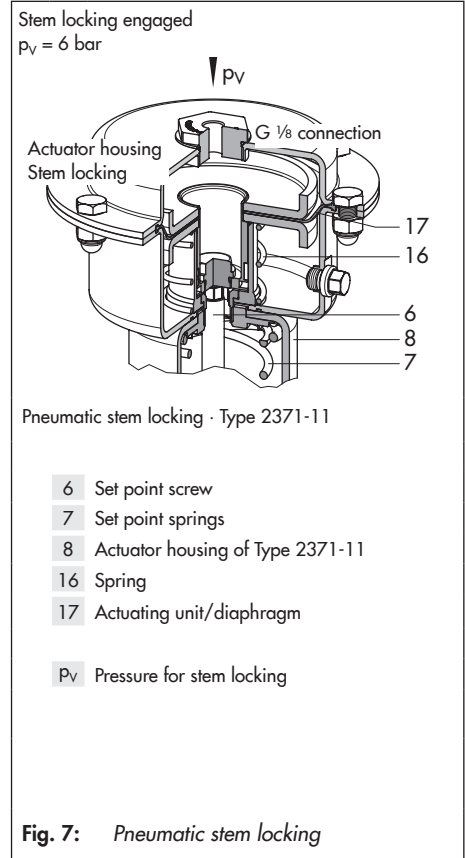

Cleaning and maintenance

Type 2371-10

To open the valve, apply a pressure $p_V = 1$ bar to the pneumatic unit. This causes the plug stem to move together with the plug out of the valve seat. A set point pressure p_C must not be applied to the regulator in this case.

How to proceed:

1. Connect the pressure hose with min. 6 mm diameter to the G 1/8 connection.
2. Apply a pressure $p_V = 1$ bar to the pneumatic stem locking. This causes the actuating unit (17) to move the plug stem together with the plug out of the valve seat and open the valve.
3. To switch the valve back to its control function, remove the pressure $p_V (= 1 \text{ bar})$ to return the pressure back to atmospheric pressure.
4. The spring (16) pulls the actuating unit (18) back. The plug stem can move again for the control task.

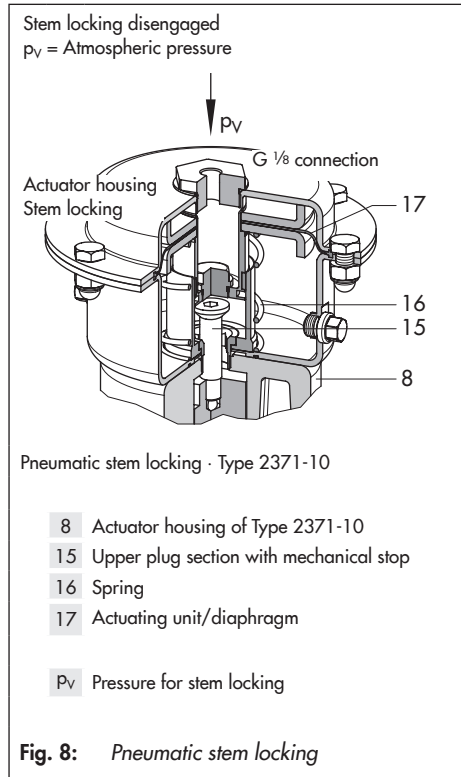

6.2 Maintenance · Replacing parts

See Fig. 1 on page 7.

The regulator is subject to natural wear. Depending on the operating conditions and duration of operation, regularly check the regulator's ability to function.

In case the output pressure rises, for example when all the consumers are closed and the valve does not shut off tightly enough. This may happen when the tight shut-off is impaired by either dirt or natural wear on the seat and plug. However, it is important to take into account that a maximum leakage of 0.05 % of the K_{VS} or C_V coefficient in the case of metal-seated plugs and 0.01 % in the case of soft-seated plugs is still permissible (see Chapter 9 on page 26).

6.3 Replacing the plug

Types 2371-10/-11 · Replacing the plug

The plug (3) is screwed into the plug support (3.1). It can **only** be removed through the inlet port. In this case, use the appropriate socket wrench to unscrew the plug.

How to proceed:

- Loosen the plug using the socket wrench
 - DN 15 to 25 (NPS ½ to 1): **width across flats 10**
 - DN 32 to 50 (NPS 1¼ to 2): **width across flats 13**
- Unscrew the plug (3) through the inlet port p_1 . Remove the two washers and the seal.

- Prior to installing a new plug: Check the seat and seat facing, so far as it is possible, for damage. In case of damage, the regulator must be replaced or repaired.

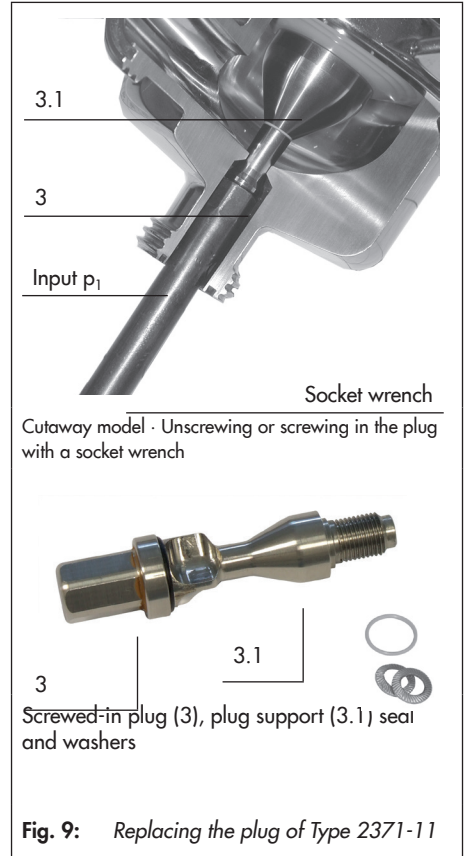

Fig. 9: Replacing the plug of Type 2371-11

We recommend also checking the diaphragm for cracks and damage as a preventive measure. See Chapter 6.4 on page 21.

Assemble the new plug (3) in the reverse order described for the disassembly. Insert the

Cleaning and maintenance

two washers into the threaded hole with the concave sides facing away from each other (as shown in the drawing).

- **Do not forget the PEEK seal!**

Tightening torque

- DN 15 to 25: **5 Nm**
(NPS ½ to 1)
- DN 32 to 50: **20 Nm**
(NPS 1¼ to 2)

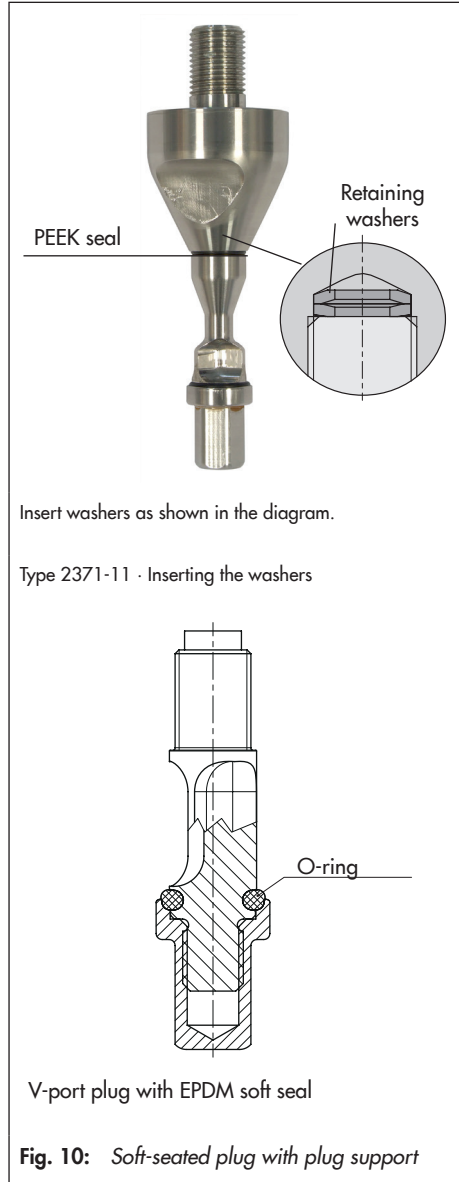

6.4 Replacing the diaphragm unit

Type 2371-11 · Diaphragm unit

In the event that the diaphragm is defective, we recommend replacing the entire diaphragm unit. This consists of the diaphragm (4), plug stem (3.2) inside of it and plug support (3.1).

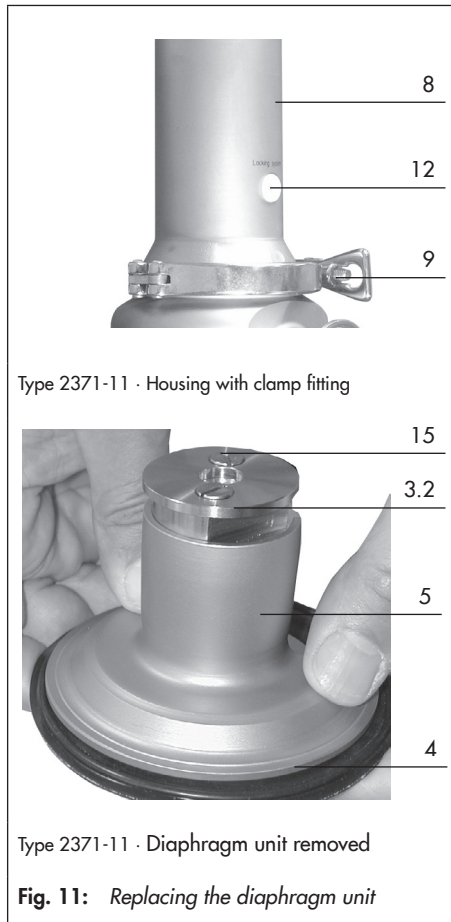

Contact SAMSON if you intend to replace just the diaphragm or plug support.

How to proceed:

See Fig. 11

1. Removing the plug (see Chapter 6.3 on page 19).

i Note

The valve and housing are loaded by the compressed springs. The valve is opened by spring force. Relieve the set point springs of tension before removing the actuator housing.

2. Remove the stopper. Undo the locking screw (12). Turn the set point screw (6) counterclockwise to relieve the tension from the set point springs. As a result, the housing is not loaded by the spring tension anymore (refer to Chapter 5.2 on page 12).
3. Release clamp fitting (9). Lift off the actuator housing (8) together with the spring assembly (7) and set point screw (6).
4. Remove the guide flange (5) together with plug stem (3.2) inside of it as well as the mechanical stop (15), plug support (3.1) and diaphragm (4).
5. Unscrew the locking screw (12). Undo both screws of the mechanical stop plate (15). Lift off plate.

i Note

The plug stem is guided by ball bearings in the guide flange. On pulling off the guide flange, the ball bearings embedded in food grade lubricant are exposed and might fall out.

- Carefully pull off the guide flange (5). Take the ball bearings out of the guiding grooves and keep them at hand for the following assembly.
- Replace the diaphragm unit with a new one.
- Reassemble the parts in the reverse order. Carefully place the actuator housing onto the valve body. Make sure that the threaded bore at the side is aligned with the locking screw and that the diaphragm rests neatly in place.
- Position the clamp fitting. Grease the groove and screw with food grade lubricant. Hit the clamp lightly with a plastic hammer and tighten the clamp screw again until the parts fit properly.

Type 2371-11 · Replacing the diaphragm unit together with the flange section

The diaphragm is replaced as a complete unit together with the guide flange (5), plug stem (3.2) inside of it as well as the plug support (3.1). It may be necessary to replace the diaphragm assembly when too much clearance arises between the guide flange and plug stem after a long service life.

How to proceed:

See Chapter 6.4 on page 21.

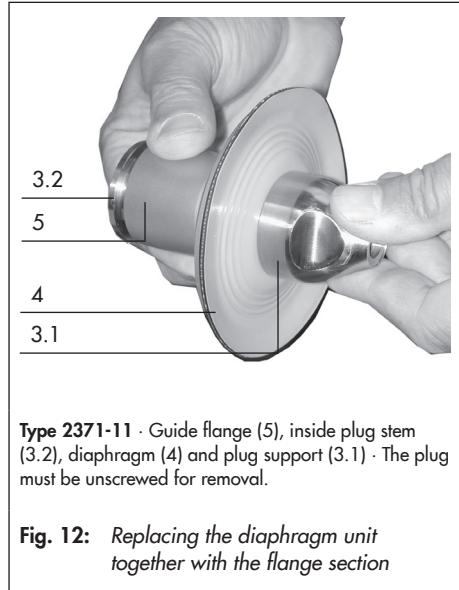

6.5 Replacing the two diaphragms

Type 2371-10 · Two diaphragms

The two diaphragms are clamped from the outside between the valve body (1) and cover (1.1). Inside the plug support and plug stem that are bolted together guide the diaphragms. The internal and external spacing rings (20) are located between the two diaphragms.

To replace the diaphragms, first pull the cover (valve bonnet) off the valve body (bottom section) to get access to the plug stem (19) and diaphragms (4.1).

How to proceed:

1. Undo and remove the four screws (16, width across flats 13). Keep in a safe place for later.
2. Use an Allen key (6 mm) to unthread the stopper (15.2). Unscrew the stop screw (15). Make sure that the inserted washer (15.1) does not get lost. Keep the parts in a safe place for later.
3. The grub screw with trunnion (12.1) acts as a locking pin and prevents the cover (1.1) and plug stem (19) from being pulled off separately. Turn the grub screw to the point where it is still held in place by the thread.

i Note

The plug stem is guided by ball bearings in the cover (valve bonnet). On pulling off the cover, the ball bearings embedded in food grade lubricant are exposed and might fall out.

4. Carefully pull off the cover.
5. Undo the grub screw (12.1). Dismantle the plug stem (19) and plug support (18) that are bolted together.
6. Remove the diaphragms (21) along with the internal and external spacing rings (20).
7. After replacing the diaphragms: Assemble in the reverse order. Tighten the four screws (16) with a tightening torque of 30 Nm.

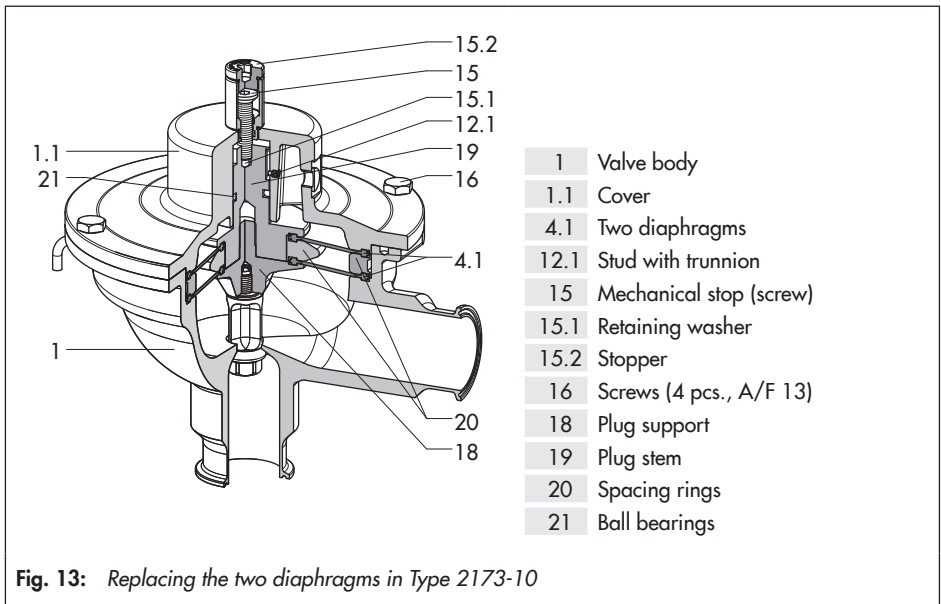

Fig. 13: Replacing the two diaphragms in Type 2173-10

6.5.1 Replacing the set point springs

Type 2371-11 · Set point springs

You need to replace the set point springs (7) with both plates to achieve a different set point range. We recommend changing the entire actuator housing (8) with set point springs (7) and set point screw (6).

How to proceed:

The regulator does not need to be removed from the pipeline.

See Chapter 6.4 on page 21, items 2 and 3.



7 After-sales service

If malfunctions or defects occur, contact the SAMSON's After-sales Service for support.

Please e-mail inquiries to:
aftersaleservice@samsongroup.com.

The addresses of SAMSON AG, its subsidiaries, representatives and service facilities worldwide can be found on the SAMSON website (▶ www.samsongroup.com), in all SAMSON product catalogs or on the back of these Mounting and Operating Instructions.

To assist diagnosis and in case of an unclear mounting situation, specify the following details (see Chapter 8 on page 25):

- Type designation and modification index
- Nominal size DN
- Serial number
- Temperature and process medium
- Is a strainer installed?
- Installation drawing showing the exact location of the regulator and all the additionally installed components (shut-off valves, pressure gauge etc.)

8 Nameplate

The specifications are located on the actual housing.

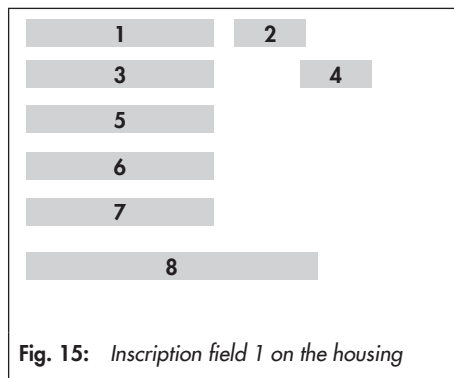

Fig. 15: Inscription field 1 on the housing

Comments:

- 1 Type designation
- 2 Modification index
- 3 Nominal size DN
- 4 Material numbers according to DIN EN
- 5 Maximum pressure in bar at 20 °C
Maximum pressure in psi at 70 °F
- 6 Maximum operating temperature in °C or °F
- 7 Flow coefficient K_{VS} (m³/h)
or C_v (US gal/min)
ME = Metal seal
EPDM = Soft seal (EPDM)
PK = Soft seal with PEEK
- 8 Serial number

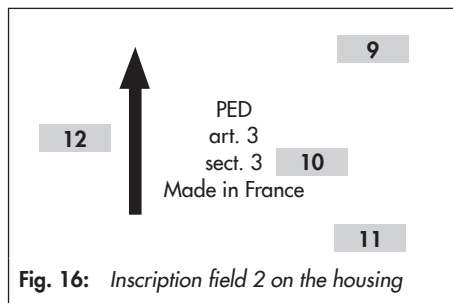

Fig. 16: Inscription field 2 on the housing

Comments:

- 9 Mark of conformity (food)
- 10 PED labeling
- 11 Made in France/year of manufacture
- 12 Arrow indicating the direction of flow

i Note

Each regulator can be clearly identified by the specifications written on the nameplate. Therefore, do not cover or write over the specifications on the nameplate.

9 Technical data

Table 1: *Materials · Material numbers according to ASTM and DIN EN*

| Pressure reducing valve | | Type 2371-10 | | Type 2371-11 | |
|-------------------------|---------------------------|--------------|------|--------------|------|
| Version | | DIN | ANSI | DIN | ANSI |
| Body | | 1.4409 | CF3M | 1.4404 | 316L |
| Plug | Metal seal | 1.4404 | 316L | 1.4404 | 316L |
| | Seal for soft-seated plug | EPDM | | | |
| Diaphragm | PTFE-coated EPDM | | | | |
| Cover | | 1.4409 | CF3M | 1.4404 | 316L |
| Springs | 1.4310 | | | | |

Table 2: *Technical data (DIN version) · All pressures (gauge)*

| Types 2371-10/-11 | | DIN | | | | | |
|--|---|--|-------|-------|--------------|----------------------------|--------------|
| Nominal size | | DN 15 | DN 20 | DN 25 | DN 32 | DN 40 | DN 50 |
| Set point ranges | Type 2371-10 | K_{VS} 10 | - | | 0.5 to 6 bar | | |
| | | K_{VS} 16 | | | - | 2.5 to 6 bar ²⁾ | 2.5 to 6 bar |
| | Type 2371-11 | 0.4 to 1.2 bar · 1 to 3 bar · 2.5 to 4.5 bar · 4 to 6 bar | | | | | |
| Pneumatic control connection | Type 2371-10 | G ¼ | | | | | |
| | CIP | G ⅛ | | | | | |
| Maximum pressure | 10 bar | | | | | | |
| Max. perm. temperatures | Operating temperature range | 0 to 160 °C | | | | | |
| | Sterilization temperature | 180 °C for up to 30 minutes | | | | | |
| Leakage class according to DIN EN 60534 | Metal seal | Class I (≤ 0.05 % of K_{VS} coefficient) | | | | | |
| | Soft seal | Class IV (≤ 0.01 % of K_{VS} coefficient) | | | | | |
| Peak-to-valley height and surface finish | External | Glass bead blasted ¹⁾ · $R_a \leq 0.6$ µm, polished | | | | | |
| | Internal | $R_a \leq 0.8$ µm, precision-lathed ¹⁾ · $R_a \leq 0.6$ µm, polished · $R_a \leq 0.4$ µm, satin finish · $R_a \leq 0.4$ µm, mirror finish | | | | | |
| Conformity |  | | | | | | |

¹⁾ Standard version

²⁾ The internal diameter of the inlet must be greater than Ø40 mm to allow correct installation of the plug

Table 3: Technical data (ANSI version) · All pressures (gauge)

| Types 2371-10/-11 | | ANSI | | | | | |
|--|-----------------------------|--|-------|-------|---------------|------------------------------|----------------|
| Nominal size | | NPS ½ | NPS ¾ | NPS 1 | NPS 1¼ | NPS 1½ | NPS 2 |
| Set point ranges | Type 2371-10 | - | | | 7.5 to 90 psi | | |
| | C _V 12 | | | | - | 37.5 to 90 psi ²⁾ | 37.5 to 90 psi |
| | C _V 20 | | | | | | |
| | Type 2371-11 | 6 to 18 psi · 15 to 45 psi · 35 to 65 psi · 60 to 90 psi | | | | | |
| Pneumatic control connection | Type 2371-10 | G ¼ | | | | | |
| | CIP | G ⅜ | | | | | |
| Maximum pressure | | 150 psi | | | | | |
| Max. perm. temperatures | Operating temperature range | 32 to 320 °F | | | | | |
| | Sterilization temperature | 356 °F for up to 30 minutes | | | | | |
| Leakage class according to ANSI/FCI 70-2 | Metal seal | Class I (≤0.05 % of C _V coefficient) | | | | | |
| | Soft seal | Class IV (≤0.01 % of C _V coefficient) | | | | | |
| Peak-to-valley height and surface finish | External | Glass bead blasted ¹⁾ · R _a ≤0.6 µm, polished | | | | | |
| | Internal | R _a ≤0.8 µm, precision-lathed ¹⁾ · R _a ≤0.6 µm, polished · R _a ≤0.4 µm, satin finish · R _a ≤0.4 µm, mirror finish | | | | | |
| Conformity | |  | | | | | |

¹⁾ Standard version

²⁾ The internal diameter of the inlet must be greater than Ø40 mm to allow correct installation of the plug

Table 4: K_{VS} and C_V coefficients

| Nominal size | DN | | | | | | NPS | | | | | |
|---------------------------------|-----------------------------------|----|---------|---------|------------------------------|----|-----------------------------------|---------|---|---------|----|---|
| | 15 | 20 | 25 | 32 | 40 | 50 | ½ | ¾ | 1 | 1¼ | 1½ | 2 |
| Version | DIN (K _{VS} coefficient) | | | | | | ANSI (C _V coefficient) | | | | | |
| Type 2371-10 | | | | | | | | | | | | |
| K _{VS} /C _V | - | | 10 | 10 · 16 | - | | 12 | | | 12 · 20 | | |
| Type 2371-11 | | | | | | | | | | | | |
| K _{VS} /C _V | 0.63 ¹⁾ · 1.0 · 3.5 | | 2 · 5.2 | | 0.75 ¹⁾ · 1.2 · 4 | | | 2.5 · 6 | | | | |

¹⁾ Plug with soft seal

10 Dimensions

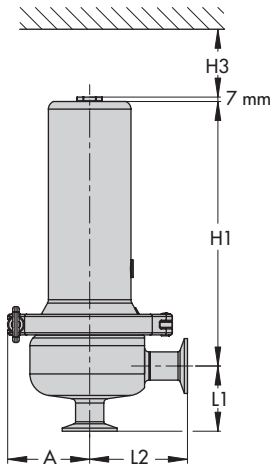

Type 2371-11 · Standard version

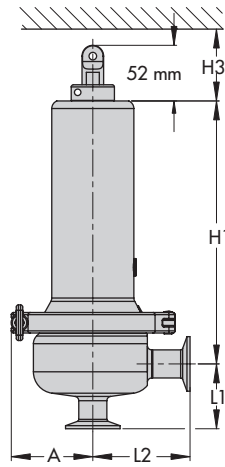

Type 2371-11 · With manual stem locking

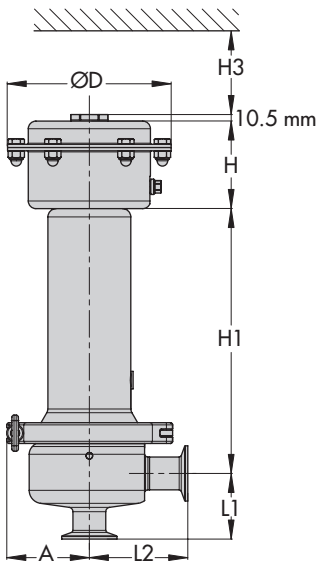

Type 2371-11 · With pneumatic stem locking

Refer to tables starting with Table 5 on page 30 for associated dimensions.

Type 2371-11 with clamp end connections is shown in these drawings.
Upon delivery, the clamp fitting (connection between the actuator housing and valve) is turned 90° in the drawing.

Fig. 17: Dimensional drawings for Type 2371-11

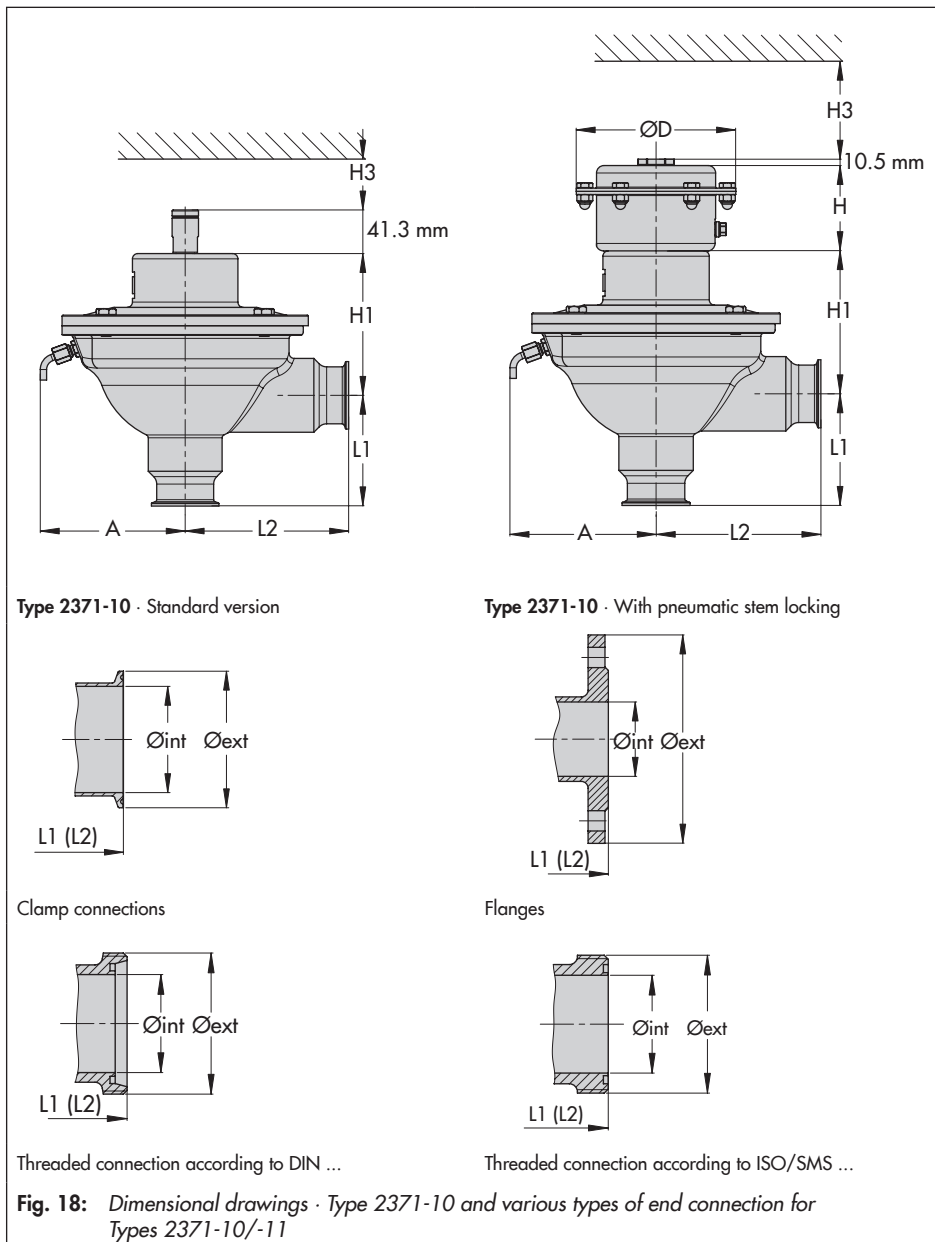

Dimensions

Table 5: Dimensions of the regulators · All dimensions in mm

| Nominal size | Type 2371-11 | | | | | | Type 2371-10 | | |
|--------------------------------------|----------------|----------------|----------------|-----------------|-----------------|----------------|-----------------|-----------------|----------------|
| | DN 15 NPS ½ | DN 20 NPS ¾ | DN 25 NPS 1 | DN 32 NPS 1¼ | DN 40 NPS 1½ | DN 50 NPS 2 | DN 32 NPS 1¼ | DN 40 NPS 1½ | DN 50 NPS 2 |
| Common dimensions | A | 85 | | | | | 145 | | |
| | H | 80 | | | | | | | |
| | H1 | 245 | | | 260 | | 180 | | |
| | H3 | 200 | | | | | | | |
| | ØD | 150 | | | | | | | |
| Weight, approx. ¹⁾ | | | | | | | | | |
| Type 2371-10/-11 | 8.5 kg/19 lb | | | 11 kg/24.3 lb | | | 15 kg/33 lb | | |
| Stem locking | | | | | | | | | |
| Pneumatic unit | 2.5 kg/5.5 lb | | | | | | | | |
| Pin | 0.1 kg/0.25 lb | | | | | | | | |

¹⁾ With welding ends

Table 6: Threaded connections · All dimensions in mm

| Nominal size | Type 2371-11 | | | | | | Type 2371-10 | | | |
|--------------------------------------|----------------|----------------|----------------|-----------------|-----------------|----------------|-----------------|-----------------|----------------|-----------|
| | DN 15 NPS ½ | DN 20 NPS ¾ | DN 25 NPS 1 | DN 32 NPS 1¼ | DN 40 NPS 1½ | DN 50 NPS 2 | DN 32 NPS 1¼ | DN 40 NPS 1½ | DN 50 NPS 2 | |
| DIN 11864-1 GS form A Series A | P_{max} | 10 bar/150 psi | | | | | | | | |
| | L1 | 55 | 55 | 60 | 60 | 65 | 70 | 105 | 105 | 105 |
| | L2 | 90 | 90 | 90 | 90 | 90 | 90 | 155 | 155 | 155 |
| | Øint | 16 | 20 | 26 | 32 | 38 | 50 | 32 | 38 | 50 |
| | Øext | RD34x1/8" | RD44x1/6" | RD52x1/6" | RD58x1/6" | RD65x1/6" | RD78x1/6" | RD58x1/6" | RD65x1/6" | RD78x1/6" |
| DIN 11864-1 GS form A Series B | P_{max} | 10 bar/150 psi | | | | | | | | |
| | L1 | 55 | 55 | 60 | 60 | 65 | 70 | 105 | 105 | 105 |
| | L2 | 90 | 90 | 90 | 90 | 90 | 90 | 155 | 155 | 155 |
| | Øint | 18.1 | 23.7 | 29.7 | 38.4 | 44.3 | 56.3 | 38.4 | 44.3 | 56.3 |
| | Øext | RD44x1/8" | RD52x1/6" | RD58x1/6" | RD65x1/6" | RD78x1/6" | RD95x1/6" | RD65x1/6" | RD78x1/6" | RD95x1/6" |
| DIN 11864-1 GS form A Series C | P_{max} | 10 bar/150 psi | | | | | | | | |
| | L1 | - | 55 | 60 | - | 65 | 70 | - | 105 | 105 |
| | L2 | - | 90 | 90 | - | 90 | 90 | - | 155 | 155 |
| | Øint | - | 15.75 | 22.1 | - | 34.8 | 47.5 | - | 34.8 | 47.5 |
| | Øext | - | RD34x1/8" | RD52x1/6" | - | RD65x1/6" | RD78x1/6" | - | RD65x1/6" | RD78x1/6" |
| DIN 11887 A Series 1 | P_{max} | 10 bar/150 psi | | | | | | | | |
| | L1 | 55 | 55 | 60 | 60 | 65 | 70 | 105 | 105 | 105 |
| | L2 | 90 | 90 | 90 | 90 | 90 | 90 | 155 | 155 | 155 |
| | Øint | 16 | 20 | 26 | 32 | 38 | 50 | 32 | 38 | 50 |
| | Øext | RD34x1/8" | RD44x1/6" | RD52x1/6" | RD58x1/6" | RD65x1/6" | RD78x1/6" | RD58x1/6" | RD65x1/6" | RD78x1/6" |
| ISO 2853 = IDF | P_{max} | 10 bar/150 psi | | | | | | | | |
| | L1 | - | - | 60 | 60 | 65 | 70 | 105 | 105 | 105 |
| | L2 | - | - | 90 | 90 | 90 | 90 | 155 | 155 | 155 |
| | Øint | - | - | 22.6 | 31.3 | 35.6 | 48.6 | 31.3 | 35.6 | 48.6 |
| | Øext | - | - | 37x1/8" | 45.9x1/8" | 50.6x1/8" | 64.1x1/8" | 45.9x1/8" | 50.6x1/8" | 64.1x1/8" |
| SMS 1146 | P_{max} | 6 bar/87 psi | | | | | | | | |
| | L1 | - | - | 60 | 60 | 65 | 70 | 105 | 105 | 105 |
| | L2 | - | - | 90 | 90 | 90 | 90 | 155 | 155 | 155 |
| | Øint | - | - | 22.6 | 29.6 | 35.6 | 48.6 | 29.6 | 35.6 | 48.6 |
| | Øext | - | - | RD40x1/6" | RD48x1/6" | RD60x1/6" | RD70x1/6" | RD48x1/6" | RD60x1/6" | RD70x1/6" |

Dimensions

Table 7: Clamp connections · All dimensions in mm

| Nominal size | Type 2371-11 | | | | | | Type 2371-10 | | | |
|---------------------------------------|---------------------|----------------|---------------------|-----------------|-----------------|----------------|-----------------|-----------------|----------------|------|
| | DN 15 NPS ½ | DN 20 NPS ¾ | DN 25 NPS 1 | DN 32 NPS 1¼ | DN 40 NPS 1½ | DN 50 NPS 2 | DN 32 NPS 1¼ | DN 40 NPS 1½ | DN 50 NPS 2 | |
| DIN 11864-3 NKS form A Series A | P_{max} | 10 bar/150 psi | | | | | | | | |
| | L1 | 55 | 55 | 60 | 60 | 65 | 70 | 105 | 105 | 105 |
| | L2 | 90 | 90 | 90 | 90 | 90 | 90 | 155 | 155 | 155 |
| | \varnothing_{int} | 16 | 20 | 26 | 32 | 38 | 50 | 32 | 38 | 50 |
| | \varnothing_{ext} | 34 | 50.5 | 50.5 | 50.5 | 64 | 77.5 | 50.5 | 64 | 77.5 |
| DIN 11864-3 NKS form A Series B | P_{max} | 10 bar/150 psi | | | | | | | | |
| | L1 | 55 | 55 | 60 | 60 | 65 | 70 | 105 | 105 | 105 |
| | L2 | 90 | 90 | 90 | 90 | 90 | 90 | 155 | 155 | 155 |
| | \varnothing_{int} | 18.1 | 23.7 | 29.7 | 38.4 | 44.3 | 56.3 | 38.4 | 44.3 | 56.3 |
| | \varnothing_{ext} | 34 | 50.5 | 50.5 | 64 | 64 | 91 | 64 | 64 | 91 |
| DIN 11864-3 NKS form A Series C | P_{max} | 10 bar/150 psi | | | | | | | | |
| | L1 | – | 55 | 60 | – | 65 | 70 | – | 105 | 105 |
| | L2 | – | 90 | 90 | – | 90 | 90 | – | 155 | 155 |
| | \varnothing_{int} | – | 15.75 | 22.1 | – | 34.8 | 47.5 | – | 34.8 | 47.5 |
| | \varnothing_{ext} | – | 34 | 50.5 | – | 64 | 77.5 | – | 64 | 77.5 |
| DIN 32676, Series A | P_{max} | 10 bar/150 psi | | | | | | | | |
| | L1 | 55 | 55 | 60 | 60 | 65 | 70 | 105 | 105 | 105 |
| | L2 | 90 | 90 | 90 | 90 | 90 | 90 | 155 | 155 | 155 |
| | \varnothing_{int} | 16 | 20 | 26 | 32 | 38 | 50 | 32 | 38 | 50 |
| | \varnothing_{ext} | 34 | 34 | 50.5 | 50.5 | 50.5 | 64 | 50.5 | 50.5 | 64 |
| DIN 32676 Series B | P_{max} | 10 bar/150 psi | | | | | | | | |
| | L1 | 55 | 55 | 60 | 60 | 65 | 70 | 105 | 105 | 105 |
| | L2 | 90 | 90 | 90 | 90 | 90 | 90 | 155 | 155 | 155 |
| | \varnothing_{int} | 18.1 | 23.7 | 29.7 | 38.4 | 44.3 | 56.3 | 38.4 | 44.3 | 56.3 |
| | \varnothing_{ext} | 50.5 | 50.5 | 50.5 | 64 | 64 | 77.5 | 64 | 64 | 77.5 |
| DIN 32676 Series C | P_{max} | 10 bar/150 psi | | | | | | | | |
| | L1 | – | 55 | 60 | – | 65 | 70 | – | 105 | 105 |
| | L2 | – | 90 | 90 | – | 90 | 90 | – | 155 | 155 |
| | \varnothing_{int} | – | 15.75 | 22.1 | – | 34.8 | 47.5 | – | 34.8 | 47.5 |
| | \varnothing_{ext} | – | 25 | 50.5 | – | 50.5 | 64 | – | 50.5 | 64 |
| ISO 2852 | P_{max} | 10 bar/150 psi | | | | | | | | |
| | L1 | – | – | 60 | 60 | 65 | 70 | 105 | 105 | 105 |
| | L2 | – | – | 90 | 90 | 90 | 90 | 155 | 155 | 155 |
| | \varnothing_{int} | – | – | 22.6 | 31.3 | 35.6 | 48.6 | 31.3 | 35.6 | 48.6 |
| | \varnothing_{ext} | – | – | 50.5 | 50.5 | 50.5 | 64 | 50.5 | 50.5 | 64 |
| BS 4825 Part 3 = ASME BPE | P_{max} | 10 bar/150 psi | | | | | | | | |
| | L1 | – | 55 ¹⁾ | 60 | – | 65 | 70 | – | 105 | 105 |
| | L2 | – | 90 ¹⁾ | 90 | – | 90 | 90 | – | 155 | 155 |
| | \varnothing_{int} | – | 15.75 ¹⁾ | 22.2 | – | 34.9 | 47.6 | – | 34.9 | 47.6 |
| | \varnothing_{ext} | – | 25 ¹⁾ | 50.5 | – | 50.5 | 64 | – | 50.5 | 64 |

¹⁾ Version according to ASME BPE only

Table 8: Flanges · All dimensions in mm

| Nominal size | Type 2371-11 | | | | | | Type 2371-10 | | | |
|---|---------------------|----------------|----------------|-----------------|-----------------|----------------|-----------------|-----------------|----------------|------|
| | DN 15 NPS ½ | DN 20 NPS ¾ | DN 25 NPS 1 | DN 32 NPS 1¼ | DN 40 NPS 1½ | DN 50 NPS 2 | DN 32 NPS 1¼ | DN 40 NPS 1½ | DN 50 NPS 2 | |
| DIN 11864-2 NF form A, Series A | P_{max} | 10 bar/150 psi | | | | | | | | |
| | L1 | 90 | 95 | 100 | 105 | 115 | 125 | 105 | 105 | 105 |
| | L2 | 90 | 95 | 100 | 105 | 115 | 125 | 155 | 155 | 155 |
| | \varnothing_{int} | 16 | 20 | 26 | 32 | 38 | 50 | 32 | 38 | 50 |
| | \varnothing_{ext} | 59 | 64 | 70 | 76 | 82 | 94 | 76 | 82 | 94 |
| DIN 11864-2 NF form A, Series B | P_{max} | 10 bar/150 psi | | | | | | | | |
| | L1 | 90 | 95 | 100 | 105 | 115 | 125 | 105 | 105 | 105 |
| | L2 | 90 | 95 | 100 | 105 | 115 | 125 | 155 | 155 | 155 |
| | \varnothing_{int} | 18.1 | 23.7 | 29.7 | 38.4 | 44.3 | 56.3 | 38.4 | 44.3 | 56.3 |
| | \varnothing_{ext} | 62 | 69 | 74 | 82 | 88 | 103 | 82 | 88 | 103 |
| DIN 11864-2 NF form A, Series C | P_{max} | 10 bar/150 psi | | | | | | | | |
| | L1 | – | 95 | 100 | – | 115 | 125 | – | 105 | 105 |
| | L2 | – | 95 | 100 | – | 115 | 125 | – | 155 | 155 |
| | \varnothing_{int} | – | 15.75 | 22.1 | – | 34.8 | 47.5 | – | 34.8 | 47.5 |
| | \varnothing_{ext} | – | 59 | 66 | – | 79 | 92 | – | 79 | 92 |
| DIN EN 1092-1 B2 or ASME B16.5 Cl 150 | On request | | | | | | | | | |

EB 2640 EN



SAMSON AKTIENGESELLSCHAFT
Weismüllerstraße 3 · 60314 Frankfurt am Main, Germany
Phone: +49 69 4009-0 · Fax: +49 69 4009-1507
samson@samsongroup.com · www.samsongroup.com