

MOUNTING AND OPERATING INSTRUCTIONS



EB 8331-4 EN

Translation of original instructions



Type 3374 Electric Actuator Version with positioner

Firmware version 3.14



Edition May 2025

Note on these mounting and operating instructions

These mounting and operating instructions (EB) assist you in mounting and operating the device safely. The instructions are binding for handling SAMSON devices. The images shown in this document are for illustration purposes only. The actual product may vary.

- ⇒ For the safe and proper use of these instructions, read them carefully and keep them for later reference.
- ⇒ If you have any additional questions not related to the contents of this document, contact SAMSON's After-sales Service (aftersaleservice@samsongroup.com).



Documents relating to the device, such as the mounting and operating instructions, are available on our website:

▶ <https://www.samsongroup.com/en/downloads/documentation>

Definition of signal words

⚠ DANGER

Hazardous situations which, if not avoided, will result in death or serious injury

⚠ WARNING

Hazardous situations which, if not avoided, could result in death or serious injury

ⓘ NOTICE

Property damage message or malfunction

ℹ Note

Additional information

💡 Tip

Recommended action

1	Safety instructions and measures.....	6
1.1	Notes on possible severe personal injury.....	7
1.2	Notes on possible personal injury.....	7
1.3	Notes on possible property damage.....	8
1.4	Warnings on the device.....	9
2	Markings on the device.....	10
2.1	Nameplate.....	10
2.2	Firmware versions.....	11
3	Design and principle of operation.....	12
3.1	Mounting types.....	12
3.2	Fail-safe action.....	12
3.3	Versions.....	13
3.3.1	Standard version.....	13
3.3.2	Version with three-key operation.....	13
3.4	Communication.....	13
3.5	Additional equipment.....	14
3.6	Technical data.....	15
3.7	Dimensions.....	18
4	Shipment and on-site transport.....	22
4.1	Accepting the delivered goods.....	22
4.2	Removing the packaging from the actuator.....	22
4.3	Transporting the actuator.....	22
4.4	Lifting the actuator.....	22
4.5	Storing the actuator.....	22
5	Installation.....	23
5.1	Installation conditions.....	23
5.2	Preparation for installation.....	23
5.3	Mounting the actuator.....	23
5.3.1	Construction with integrated yoke (form B).....	23
5.3.2	Construction with ring nut (form A).....	25
5.4	Installing additional equipment.....	27
5.4.1	Retrofitting limit contacts.....	28
5.4.2	Retrofitting electronic limit contacts.....	30
5.4.3	Retrofitting RS-485 module.....	30
5.5	Electrical connection.....	30
5.5.1	Electrical connection (standard version).....	32
5.5.2	Electrical connection for special version with three-key operation.....	34
6	Operation.....	36
6.1	Device overview and operating controls.....	36
6.1.1	Display.....	36
6.1.2	Rotary pushbutton.....	38
6.1.3	Three-key operation.....	38
7	Start-up and configuration.....	39
7.1	Initializing the actuator.....	39
7.2	Configuring the actuator.....	39
7.2.1	Fast configuration level.....	40
7.3	Selecting the application.....	40
7.4	Adjusting the limit contacts.....	42
7.5	Setting up communication.....	43
7.6	Modbus RTU protocol.....	43

8	Operation.....	45
8.1	Automatic mode.....	45
8.1.1	Information level.....	45
8.1.2	Operating level.....	45
8.1.2.1	Selecting the operating mode.....	45
8.1.2.2	Determining the reading direction.....	45
8.1.2.3	Switching on the backlight.....	46
8.2	Manual mode.....	46
8.2.1	Mechanical override.....	46
8.2.2	Special version with handwheel.....	46
8.2.3	MAN mode.....	47
8.3	Operation using memory pen.....	47
8.3.1	Memory and data logging function.....	47
8.3.2	Command mode.....	47
8.4	Service mode.....	48
8.4.1	Zero calibration.....	48
8.4.2	Initializing the actuator.....	49
8.4.3	Restarting the actuator (reset).....	49
8.4.4	Reset to default settings.....	49
8.4.5	Testing display.....	49
8.4.6	Measuring the transit time.....	49
8.4.7	Displaying the actual value and changing the set point (PID and POSF applications).....	50
9	Malfunctions.....	51
9.1	Troubleshooting.....	51
9.2	Emergency action.....	51
9.3	Error messages.....	51
10	Servicing.....	55
11	Decommissioning.....	56
12	Removal.....	57
12.1	Construction with integrated yoke.....	57
12.2	Construction with ring nut.....	57
13	Repairs.....	59
13.1	Returning the actuator to SAMSON.....	59
14	Disposal.....	60
15	Certificates.....	61
16	Appendix A (configuration instructions).....	68
16.1	Key number.....	68
16.2	Input signal.....	69
16.3	Direction of action.....	70
16.4	End position guiding.....	70
16.5	Position feedback signal.....	71
16.6	Binary input.....	71
16.7	Binary output.....	72
16.8	Electronic limit contacts.....	73
16.9	Restart.....	74
16.10	Blockage.....	74
16.11	Travel.....	75
16.12	Characteristic.....	76
16.13	Applications.....	78
16.13.1	Positioner.....	78

16.13.2	PID controller.....	78
16.13.3	Two-step mode.....	81
16.13.4	Three-step mode.....	82
16.13.5	Temperature closed-loop control upon input signal failure.....	82
16.14	Levels and parameters.....	84
16.14.1	Operating level.....	84
16.14.2	Configuration level.....	85
16.14.3	Information level.....	89
16.14.4	Service level.....	90
16.14.5	Communication level.....	91
16.14.6	Characteristic level.....	92
16.15	Further codes on the display.....	92
16.16	Excerpt from Modbus list.....	93
17	Appendix B.....	97
17.1	Parts for retrofitting and accessories.....	97
17.2	After-sales service.....	98

1 Safety instructions and measures

Intended use

The Type 3374 Electric Actuator is designed to operate a mounted globe valve used in industrial applications as well as in heating, ventilation and air-conditioning systems.

The digital positioner ensures a predetermined assignment of the valve position to the input signal.

The actuator is designed to operate under exactly defined conditions (e.g. thrust, travel). Therefore, operators must ensure that the actuator is only used in operating conditions that meet the specifications used for sizing the actuator at the ordering stage. In case operators intend to use the actuator in applications or conditions other than those specified, contact SAMSON.

SAMSON does not assume any liability for damage resulting from the failure to use the device for its intended purpose or for damage caused by external forces or any other external factors.

⇒ Refer to the technical data for limits and fields of application as well as possible uses (see Chapter 3).

Reasonably foreseeable misuse

The actuator is not suitable for the following applications:

- Use outside the limits defined during sizing and by the technical data
- Outdoor use

Furthermore, the following activities do not comply with the intended use:

- Use of non-original spare parts
- Performing service and repair work not described

Qualifications of operating personnel

The product (Type 3374) must be mounted, started up, serviced and repaired by fully trained and qualified personnel only; the accepted industry codes and practices must be observed. According to the mounting and operating instructions, trained personnel refers to individuals who are able to judge the work they are assigned to and recognize possible hazards due to their specialized training, their knowledge and experience as well as their knowledge of the applicable standards.

Personal protective equipment

No personal protective equipment is required for the direct handling of the product (Type 3374). Work on the control valve on which the device is mounted or on the pipeline may be necessary when mounting or removing the device.

- ⇒ Observe the requirements for personal protective equipment specified in the valve documentation.
- ⇒ Check with the plant operator for details on further protective equipment.

Revisions and other activities

Revisions, conversions or other modifications of the product (Type 3374) are not authorized by SAMSON. They are performed at the user's own risk and may lead to safety hazards, for example. Furthermore, the product may no longer meet the requirements for its intended use. Use of the device is no longer permitted in this case.

Safety features

The actuator automatically switches off when one of the end positions is reached.

Upon supply voltage failure, a valve, which has a Type 3374 Electric Actuator with fail-safe action mounted on it, moves to a certain fail-safe position. The direction of the fail-safe action is specified on the nameplate of SAMSON actuators.

Warning against residual hazards

The product (Type 3374) has a direct influence on the control valve. To avoid personal injury or property damage, plant operators and operating personnel must prevent hazards that could be caused in the control valve by the process medium, the operating pressure, the signal pressure or by moving parts by taking appropriate precautions.

Plant operators and operating personnel must observe all hazard statements, warnings and caution notes in these mounting and operating instructions, especially for installation, start-up and service work.

Responsibilities of the operator

Operators are responsible for proper use and compliance with the safety regulations. Operators are obliged to provide these mounting and operating instructions to the operating personnel and to instruct them in proper operation. Furthermore, operators must ensure that operating personnel or third parties are not exposed to any danger.

Responsibilities of operating personnel

Operating personnel must read and understand these mounting and operating instructions as well as the specified hazard statements, warnings and caution notes. Furthermore, operating personnel must be familiar with the applicable health, safety and accident prevention regulations and comply with them.

Referenced standards, directives and regulations

The product (Type 3374) with a CE marking fulfills the requirements of the following Directives:

- RoHS Directive 2011/65/EU
- EMC Directive 2014/30/EU
- Low-voltage Directive 2014/35/EU

The declarations of conformity and certificates are included in Chapter 15.

The product (Type 3374) with a CE marking is designed for use in low voltage installations.

- ⇒ For wiring, maintenance and repair, observe the relevant safety regulations.

Referenced documents

The following documents apply in addition to these mounting and operating instructions:

Mounting and operating instructions of the valve on which the electric actuator is mounted, e.g. for SAMSON valves:

- ▶ EB 3018 for Type 42-36 E Pressure-independent Control Valve (PICV)
- ▶ EB 5861 for Type 3260 Three-way Valve
- ▶ EB 5868-1 for Type 3213 and Type 3214 Globe Valves balanced by a diaphragm
- ▶ EB 5868/5869 for Type 3213 and Type 3214 Globe Valves
- ▶ EB 8012 for Type 3241 Globe Valve, ANSI and JIS version
- ▶ EB 8015 for Type 3241 Globe Valve, DIN version
- ▶ EB 8026 for Type 3244 Three-way Valve
- ▶ EB 8111/8112 for Type 3321 Globe Valve
- ▶ EB 8113/8114 for Type 3323 Three-way Valve

- ▶ EB 8131/8132 for Type 3531 Globe Valve for Heat Transfer Oil

- ▶ EB 8135/8136 for Type 3535 Three-way Valve for Heat Transfer Oil

1.1 Notes on possible severe personal injury

⚠ DANGER

Risk of fatal injury due to electric shock.

- ⇒ Before connecting wiring, performing any work on the device or opening the device, disconnect the supply voltage and protect it against unintentional reconnection.
- ⇒ Only use protective equipment that can be protected against unintentional reconnection of the power supply.
- ⇒ Do not remove any covers to perform adjustment work on live parts.

The electric actuator is protected against water jets (IP65; older versions are protected against spray water, IP54).

- ⇒ Use the cable grip of the mounted cable glands.
- ⇒ Mount cable glands on versions with IP54.

1.2 Notes on possible personal injury

⚠ WARNING

Crush hazard arising from moving parts.

The following applies to the form-fit version of the electric actuator:

The electric actuator contains moving parts (actuator and plug stems), which can injure hands or fingers if inserted into the actuator.

- ⇒ Do not insert hands or fingers into the yoke while the valve is in operation.
- ⇒ Before performing any work on the control valve or opening the electric device, disconnect the supply voltage and protect it against unintentional reconnection.
- ⇒ Do not impede the movement of the actuator or plug stem by inserting objects into their path.

⚠ WARNING

Risk of personal injury due to incorrect operation, use or installation as a result of information on the device being illegible.

Over time, markings, labels and nameplates on the device may become covered with dirt or become illegible in some other way. As a result, hazards may go unnoticed and the necessary instructions not followed. There is a risk of personal injury.

- ⇒ Keep all relevant markings and inscriptions on the device in a constantly legible state.
- ⇒ Immediately renew damaged, missing or incorrect nameplates or labels.

⚠ WARNING

Risk of injury through a power surge.

The serial interface of the electric actuator is not fitted with a surge protector.

- ⇒ Ensure that surge protection is provided upon connecting cables.

1.3 Notes on possible property damage

ⓘ NOTICE

Risk of damage to the electric actuator due to the supply voltage exceeding the permissible tolerances.

The electric actuator is designed for use according to regulations for low-voltage installations.

- ⇒ Observe the permissible tolerances of the supply voltage.

ⓘ NOTICE

Risk of damage to the electric actuator due to over-torquing.

Observe the specified torques when tightening the mounting parts of Type 3374 Electric Actuators. Over-torquing leads to parts wearing out more quickly.

- ⇒ Observe the specified tightening torque.

ⓘ NOTICE

Risk of damage to the electric actuator due to incorrect operation of the manual override.

- ⇒ The actuator stem of the electric actuator can be adjusted manually.
- ⇒ Do not operate the manual override while the actuator is in operation.
- ⇒ Only operate the manual override of actuators without fail-safe action in the de-energized state.

ⓘ NOTICE

Risk of actuator damage due to incorrect wiring of the binary inputs.

- ⇒ Wire the binary inputs as floating contacts.

ⓘ NOTICE

Risk of damage to the connecting cables as a result of being bent, twisted, pulled or squeezed.

- ⇒ Use the mounted cable glands.

1.4 Warnings on the device

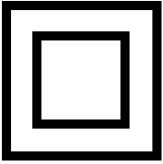
Warning symbols	Meaning	Location on the device
	<p>General warning ⇒ Refer to the mounting and operating instructions.</p>	<p>Inside the actuator</p>
	<p>Class of protection II (only applies when the housing cover is attached and fastened) ⇒ Refer to the mounting and operating instructions.</p>	<p>Actuator housing</p>

2 Markings on the device

2.1 Nameplate

The nameplate shown was up to date at the time of publication of this document. The nameplate on the device may differ from the one shown.

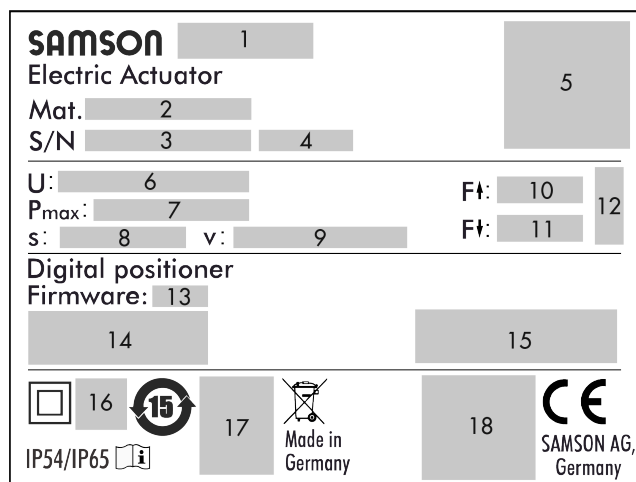

- 1 Type designation
- 2 Material number
- 3 Serial number
- 4 Date of manufacture
- 5 Identification code (scannable)
- 6 Supply voltage; power line frequency
- 7 Power consumption
- 8 Rated travel
- 9 Stroking speed
- 10 Thrust (actuator stem retracts)
- 11 Thrust (actuator stem extends)
- 12 Direction of action (fail-safe action)



Retracts



Extends

- 13 Firmware version
- 14 Input and output signal
- 15 Limit contacts



Mechanical limit contacts



Electronic limit contacts

- 16 Other mark of conformity
- 17 Testing according to DIN EN 14597
- 18 Other mark of conformity

2.2 Firmware versions

Firmware revisions	
Old	New
3.10	3.11
	Internal revisions
3.11	3.12
	Baud rate 38400 is no longer available for Modbus.
	Communication parameters can only be changed after the key number has been entered.
	Special version with three-key operation is available.
	The actuator version with three-key operation allows the set point to be changed and displayed on the start screen in 'PID controller' and 'Temperature closed-loop control upon input signal failure' applications. The key number does not need to be entered beforehand in this case.
3.12	Extended temperature measurement: In the 'PID controller' application, temperatures can be additionally measured using a Pt1000 sensor at input 1 and input 2. The Code c85 (unit) must be set to '°C' and Code c01 (source) to 'Pt1000'. The measuring range has a fixed range (-50 °C to +150 °C). The measured values can only be read over two Modbus holding registers and not processed any further in the actuator.
	3.13
3.13	For 'Temperature closed-loop control upon input signal failure' (POSF) application: when the input signal is received over the interface, the switchover from the positioner to PID controller also occurs after the connection to the Modbus master has been interrupted.
	3.14
3.13	Final test with self-calibration and self-diagnosis added

3 Design and principle of operation

The Type 3374 Electric Actuator is a linear actuator, which is used in combination with SAMSON valves in industrial plants as well as in heating, ventilation and air-conditioning systems.

The force of the stepper motor is transmitted to the actuator stem over gearing and a ball screw drive. Continuous signals issued by an electronic controller control the positioner of the electric actuator. The motor is switched off by torque switches or in case of overload.

There are different types of control depending on the application selected:

Positioner

The actuator stem follows the input signal.

PID controller

The set point is controlled by a PID controller.

Two-step mode

The actuator stem is moved by an on/off signal to the top or bottom end position.

Three-step mode

The actuator stem's position is controlled by a three-step signal and can remain in any position.

Temperature closed-loop control upon input signal failure

In normal operation, the actuator behaves in the same way as the 'Positioner' application. A PID controller takes over control upon input signal failure.

3.1 Mounting types

Construction with integrated yoke

The Type 3374 Actuator is available with an integrated yoke (see Fig. 1).



Fig. 1: Construction with integrated yoke (form B)

Construction with ring nut

The Type 3374 Actuator is available with an M30x1.5 ring nut including the necessary stem connecting parts (see Fig. 2).



Fig. 2: Construction with ring nut (form A)

3.2 Fail-safe action

The Type 3374 Actuator is available with fail-safe action. The actuators with fail-safe action have a spring assembly and an electromagnet. The actuator is moved by the force of the spring to the fail-safe position when the electromagnet is de-energized. The direction of action depends on the actuator version and cannot be reversed.

- **“Actuator stem extends” fail-safe action:**
The actuator stem extends upon supply voltage failure.
- **“Actuator stem retracts” fail-safe action:**
The actuator stem retracts upon supply voltage failure.

NOTICE

Increased wear and shortened service life of the actuator.

⇒ Do not use the fail-safe action to control the valve position.

Testing according to DIN EN 14597

Type 3374 Electric Actuators with “Actuator stem extends” fail-safe action which have a test mark on their nameplate are tested by the German technical surveillance association TÜV according to DIN EN 14597 in combination with different SAMSON valves (the register number is available on request).

3.3 Versions

3.3.1 Standard version

The operating controls are located underneath the housing cover.

3.3.2 Version with three-key operation

In the special version of the actuator with three-key operation, the actuator is not operated using the rotary pushbutton. Instead, three keys on the cover are used for operation. This actuator version can be operated without having to remove the housing cover.

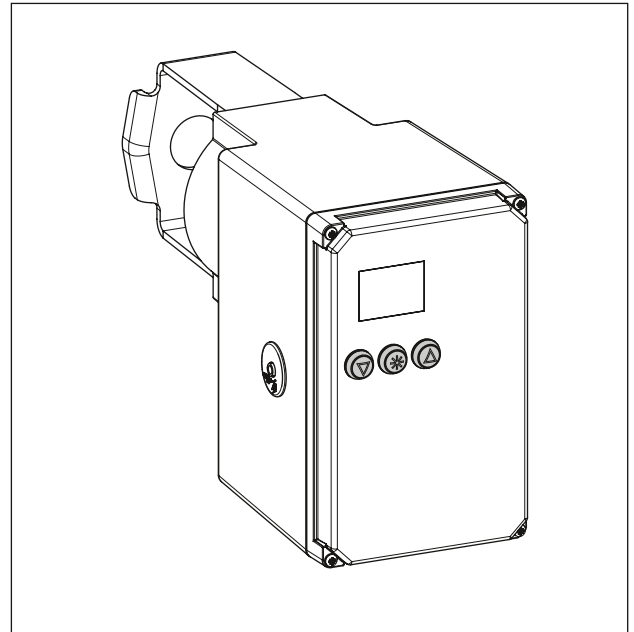

Fig. 3: Special version with three-key operation

3.4 Communication

Serial interface

The actuator is fitted with an RS-232 serial interface as standard. This allows communication with TROVIS-VIEW using SSP protocol.

WARNING

Risk of injury through a power surge.

The serial interface of the electric actuator is not fitted with a surge protector.

⇒ Ensure that surge protection is provided upon connecting cables.

NOTICE

Risk of actuator damage due to overvoltage.

⇒ Ensure that surge protection is provided upon connecting cables.

i Note

The serial interface is exclusively intended for servicing purposes. It must only be used temporarily and not permanently.

i Note

The actuator can also be fitted with an optional RS-485 module (see Chapter 5).

The actuator can be configured with the TROVIS-VIEW software. In this case, the serial interface on the actuator is used to connect the actuator to the computer. The TROVIS-VIEW software enables the user to easily configure the positioner as well as view process parameters online.

⇒ See Chapter 7.

i Note

TROVIS-VIEW can be downloaded free of charge from the SAMSON website at ► www.samsongroup.com > DOWNLOADS > Software & Drivers > TROVIS-VIEW Further information on TROVIS-VIEW (e.g. system requirements) is available on our website and in the Data Sheet ► T 6661 as well as in the Operating Instructions ► EB 6661.

3.5 Additional equipment

The actuator can be equipped with the following additional equipment to influence the tasks of control equipment:

- Mechanical limit contacts
- Electronic limit contacts

Mechanical limit contacts

Mechanical limit contacts consist of two floating changeover switches. Their switching positions can be changed independently from one another by continuously adjustable cam disks.

The limit contacts are suitable for retrofitting. The retrofitting and adjustment of the mechanical limit contacts is described in Chapter 5.

Electronic limit contacts

The two electronic limit contacts consist of relays with changeover contacts. The floating contacts can be used as either make or break contacts to influence the tasks of control equipment.

In contrast to the mechanical limit contacts, the electronic limit contacts no longer function after a supply voltage failure. The relays are de-energized and the contacts change to the idle state. The retrofitting of the electronic limit contacts is described in Chapter 5 and their adjustment in Chapter 7. The

electronic limit contact can be triggered by the actuator stem position exceeding or falling below an adjustable switching point.

- **Triggered when the actuator stem moves beyond the switching point:**

The limit contact is activated when the actuator stem moves beyond the switching point. The limit contact is deactivated when the actuator stem moves below the switching point plus hysteresis.

- **Triggered when the actuator stem moves below the switching point:**

The limit contact is activated when the actuator stem moves below the switching point. The limit contact is deactivated when the actuator stem moves beyond the switching point plus hysteresis.

i Note

An activated limit contact remains permanently active if the switching point is smaller or larger than the hysteresis. This limit contact can only be deactivated by a restart (see Chapter 8) or by resetting to 'NONE' (c24, c27).

3.6 Technical data

Table 1: Technical data · General

Type 3374	-10	-11	-15	-17	-21	-25	-26	-27	-31	-35	-36
Form ¹⁾	B		A		B	A			B	A	
Fail-safe action	Without				Actuator stem extends				Actuator stem retracts		
Testing according to DIN EN 14597	-				✓				-		
Rated travel in mm	30	15	30		15	30	15	30	15	30	15
Limited travel range	10 to 100 % of the rated travel										
Motor switch-off	Torque switches										
Operating mode	S1 - 100 % according to EN 60034-1										
Permissible temperature ranges ²⁾											
Ambient	5 to 60 °C										
Storage	-25 to +70 °C										
Humidity	5 to 95 % relative humidity, no dew formation										
Material	Housing and cover: Plastic (glass-fiber reinforced PPO)										
Safety											
Degree of protection ³⁾	IP65 according to EN 60529 with mounted cable glands, suspended mounting position not permitted according to EN 60664-1										
Class of protection ³⁾	II according to EN 61140										
Device safety ³⁾	According to EN 61010-1										
Noise immunity	According to EN 61000-6-2 and EN 61326-1										
Noise emission	According to EN 61000-6-3 and EN 61326-1										
Conformity	CE										

¹⁾ Form A: with ring nut; form B: with mounted yoke

²⁾ The permissible medium temperature depends on the valve on which the electric actuator is mounted. The limits in the valve documentation apply.

³⁾ Only when the housing cover is attached and fastened

Table 2: Technical data · Version with positioner

Type 3374		-10	-11	-15	-17	-21	-25	-26	-27	-31	-35	-36
Thrust in kN												
Standard	Extends	2.5	2.5	2.5	5	2	1.8	2	3	2	2.1	2
	Retracts	2.5	2.5	2.5	5	0.5	2.1	0.5	0.5	0.5	1.8	0.5
Faster motor	Extends	1.25	1.25	1.25	-	-	-	-	-	-	-	-
	Retracts	1.25	1.25	1.25	-	-	-	-	-	-	-	-
Nominal thrust of safety spring (for rated travel) in kN		-	-	-	-	2	1.8	2	3	0.5	1.8	0.5
Manual override		4 mm hex wrench or electric ¹⁾					Electric					
Stroking speed in mm/s												
Standard motor/normal speed		0.25	0.25	0.25	0.125	0.25	0.125	0.25	0.125	0.25	0.125	0.25
Standard motor/fast speed		0.5	0.5	0.5	0.25	0.5	0.25	0.5	0.25	0.5	0.25	0.5
Faster motor/normal speed		0.5	0.5	0.5	-	-	-	-	-	-	-	-
Faster motor/fast speed		1	1	1	-	-	-	-	-	-	-	-
In the event of fail-safe action		-	-	-	-	1.25	1.25	1.25	1.25	1.25	1.25	1.25
Transit time in s for rated travel												
Standard motor/normal speed		120	60	120	240	60	240	60	240	60	240	60
Standard motor/fast speed		60	30	60	120	30	120	30	120	30	120	30
Faster motor/normal speed		60	30	60	-	-	-	-	-	-	-	-
Faster motor/fast speed		30	15	30	-	-	-	-	-	-	-	-
In the event of fail-safe action		-	-	-	-	12	24	12	24	12	24	12
Electrical connection												
Supply voltage; power line frequency		24 V (±15 %), 50 to 60 Hz (tolerance: 47 to 63 Hz) and 24 V DC (±15 %) 100 to 240 V (tolerance: 85 to 264 V), 50 to 60 Hz (tolerance: 47 to 63 Hz)										
Power consumption												
24 V AC in VA												
Normal		12.5			19	18	25	18	25	18	25	18
Fast		16.5			-	23	-	23	-	23	-	23
24 V DC in W												
Normal		7.5			13	11.5	17	11.5	17	11.5	17	11.5
Fast		11			-	15	17	15	17	15	17	15
100 to 240 V AC in VA												
Normal		13.8 to 20			22	19.8 to 26	28	19.8 to 26	28	19.8 to 26	28	19.8 to 26
Fast		13.8 to 20			-	19.8 to 26	28	19.8 to 26	28	19.8 to 26	28	19.8 to 26
Additional equipment												
Limit contacts	Mechanical	Two adjustable limit contacts with mechanical changeover switches; Max. 240 V AC, max. 1 A, without contact protection ²⁾										
	Electronic	Two adjustable limit contacts with relay and changeover switches; Max. 240 V AC, max. 1 A, without contact protection ²⁾										
RS-485 module		Module for Modbus RTU communication										
Weight in kg (approx.)		3.5	3.5	3.6	3.6	4.2	5.7	4.3	6.1	3.8	5.7	3.9

¹⁾ Special version with handwheel on request

²⁾ Contact protection with suitable spark suppression must be fitted for the switching contact. Observe the manufacturer's specifications concerning the connected load to select the appropriate spark suppression. A fuse, which is suitable for the application's circuit, must be used for the short-circuit and overload protection.

Table 3: Technical data · Positioner

Type 3374		
Input	Current input	0/4 to 20 mA, adjustable, $R_i = 50 \Omega$
	Voltage input	0/2 to 10 V, adjustable, $R_i = 20 k\Omega$
	Pt1000 input ¹⁾	Measuring range: -50 to +150 °C, 300 μ A
	Binary input ²⁾	Activation by jumpering the terminals, not galvanically isolated
Output	Current output	0/4 to 20 mA, adjustable; error indication 24 mA
	Resolution	1000 steps or 0.02 mA
	Load	Max. 200 Ω
	Voltage output	0/2 to 10 V, adjustable; error indication 12 V
	Resolution	1000 steps or 0.01 V
	Load	Min. 5 k Ω
Binary output	Floating, max. 240 V AC, max. 1 A, without contact protection ³⁾	
Applications	Positioner	The travel follows the input signal
	PID controller	Fixed set point control
	Two-step mode	Two-step mode, floating binary input for actuation
	Three-step mode	Three-step mode, floating binary input for actuation
	Temperature closed-loop control upon input signal failure	The integrated PID controller uses a fixed set point for closed-loop control after the input signal fails.
Display	Icons for functions, codes and text field; with backlight	
Rotary pushbutton	Operating control for on-site operation to select and confirm codes and values	
Interface	RS-232, for point-to-point connection to communication participants or for memory pen; permanently installed; connection: RJ-12 jack	

¹⁾ For PID controller (PID) and Temperature closed-loop control upon input signal failure (POSF) applications only

²⁾ For two-step mode (2STP) and three-step mode (3STP) applications

³⁾ Contact protection with suitable spark suppression must be fitted for the switching contact. Observe the manufacturer's specifications concerning the connected load to select the appropriate spark suppression. A fuse, which is suitable for the application's circuit, must be used for the short-circuit and overload protection.

3.7 Dimensions

i Note

The dimension h_x indicates the minimum clearance required to be able to operate the actuator. Sufficient clearance must be available to facilitate wiring and operation. SAMSON recommends a minimum clearance of 600 mm.

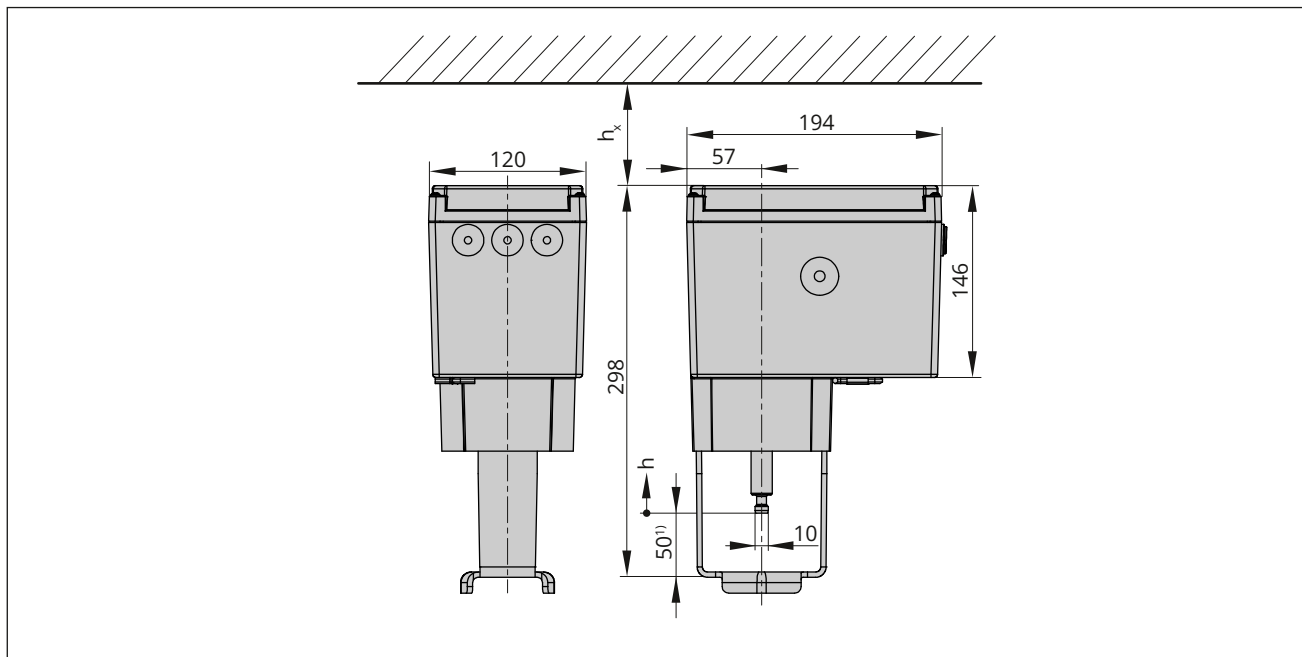

Fig. 4: Dimensions in mm · Type 3374-10, -11, -21 and -31 (form B)

¹) When the actuator stem is fully extended

Legend for Fig. 4:

Type 3374	Dimension h	Dimension h_x
-10	30 mm	≥60 mm
-11	15 mm	
-21	15 mm	
-31	15 mm	

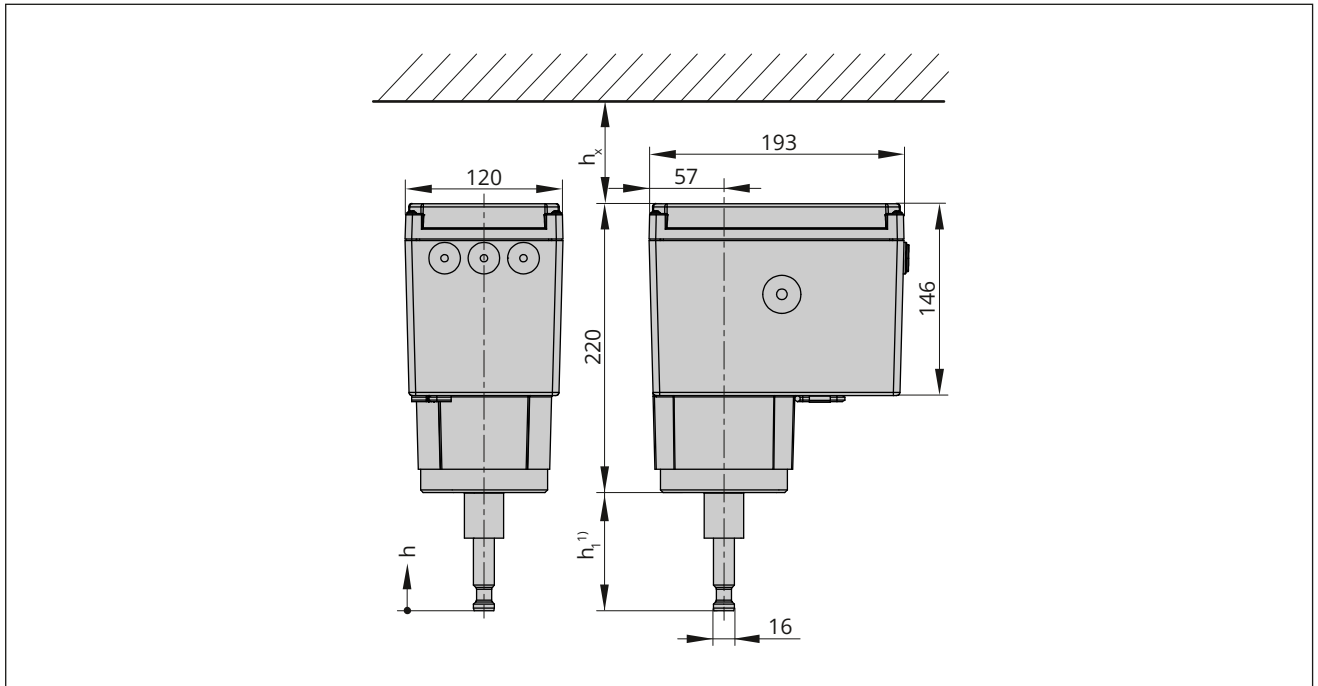

Fig. 5: Dimensions in mm · Type 3374-15, -17, -26 and -36 (form A)

¹⁾ When the actuator stem is fully extended

Legend for Fig. 5:

Type 3374	Dimension h	Dimension h ₁	Dimension h _x
-15	30 mm	90 mm	≥100 mm
-17			
-26	15 mm	75 mm	
-36			

Design and principle of operation

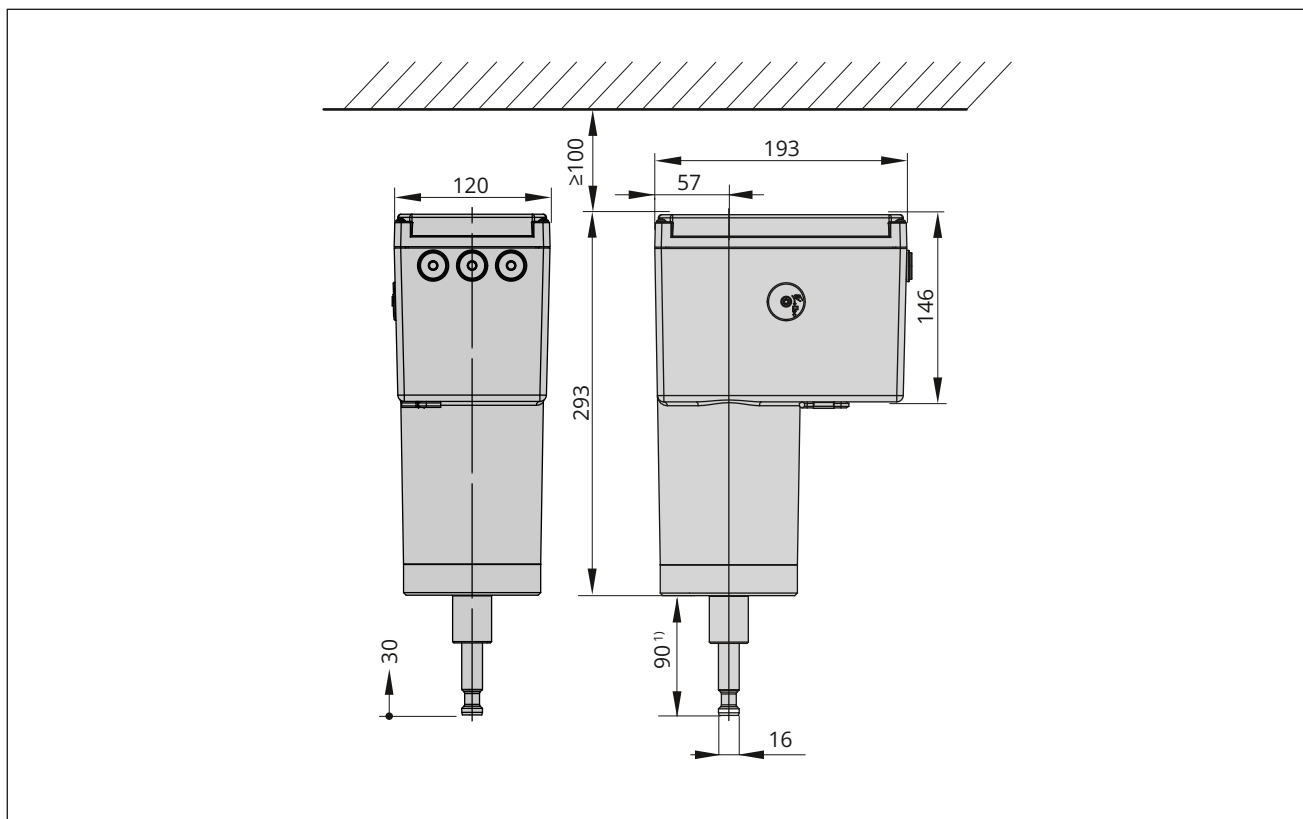

Fig. 6: Dimensions in mm · Type 3374-25 and -27, form A version

¹⁾ When the actuator stem is fully extended

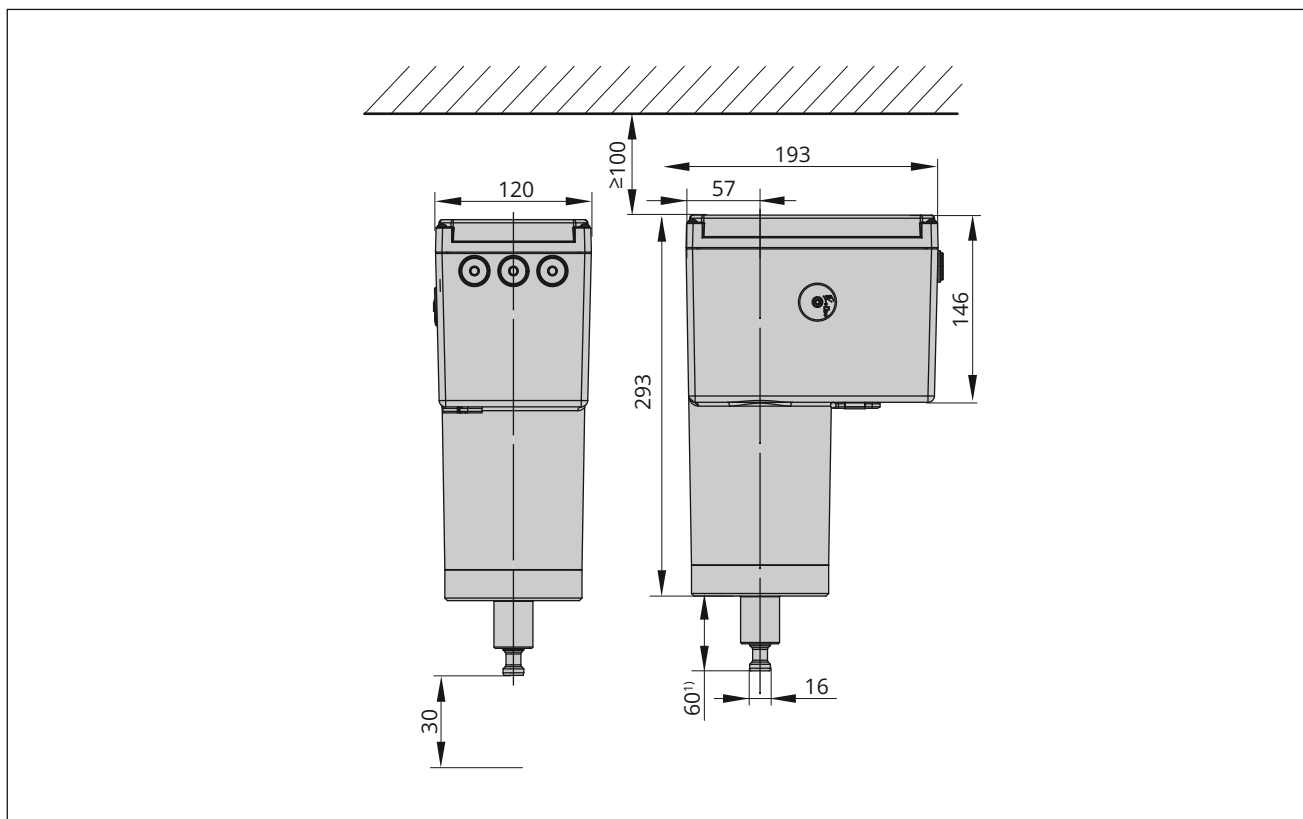

Fig. 7: Dimensions in mm · Type 3374-35, form A version

¹⁾ When the actuator stem is fully retracted

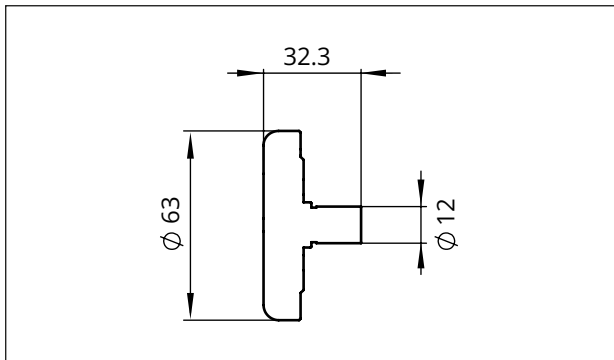

Fig. 8: Dimensions in mm · Handwheel as special version

4 Shipment and on-site transport

The work described in this chapter is to be performed only by personnel appropriately qualified to carry out such tasks.

4.1 Accepting the delivered goods

After receiving the shipment, proceed as follows:

1. Compare the shipment received with the delivery note.
2. Check the shipment for transportation damage. Report any damage to SAMSON and the forwarding agent (refer to delivery note).

4.2 Removing the packaging from the actuator

i Note

Do not remove the packaging until immediately before mounting and start-up.

1. Remove the packaging from the electric actuator.
2. Check scope of delivery.
3. Dispose of the packaging in accordance with the valid regulations.

Table 4: Scope of delivery

1x Type 3374-xx Electric Actuator	
1x IP 8331-4 EN document	
for Types 3374-10, -11, -21, -31:	
1x Accessory 1400-6817, consisting of	
	2x stem connector parts for Ø 10 mm stem
	2x M5 hex screws
for Types 3374-15, -17, -25, -26, -27, -35, -36:	
1x Accessory 0900-2679, consisting of	
	2x stem connector parts for Ø 16 mm stem
	2x M6 screws
	1x M30x1.5 ring nut

4.3 Transporting the actuator

- Protect the actuator against external influences (e.g. impact).
- Protect the actuator against moisture and dirt.
- Observe the permissible transportation temperature range of -25 to +70 °C.

4.4 Lifting the actuator

Due to the low service weight, lifting equipment is not required to lift the electric actuator.

4.5 Storing the actuator

! NOTICE

Risk of electric actuator damage due to improper storage.

- ⇒ Observe the storage instructions.
- ⇒ Avoid longer storage periods.
- ⇒ Contact SAMSON in case of different storage conditions or longer storage times.

i Note

SAMSON recommends to regularly check the electric actuator and the prevailing storage conditions during long storage periods.

Storage instructions

- Protect the electric actuator against external influences (e.g. impact).
- Protect the electric actuator against moisture and dirt.
- Make sure that the ambient air is free of acids or other corrosive media.
- Observe the permissible storage temperature from -20 to +70 °C.
- Do not place any objects on the electric actuator.

5 Installation

The work described in this chapter is to be performed only by personnel appropriately qualified to carry out such tasks.

5.1 Installation conditions

Work position

If not described otherwise in the valve documentation, the work position for the control valve is the front view looking onto the operating controls.

Point of installation

The electric actuator must only be used indoors.

Mounting position

The control valve can be installed in the pipeline in any desired position. However, a suspended mounting position of the actuator is not permissible.

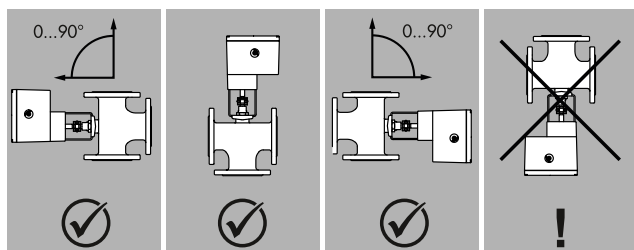

Fig. 9: Mounting position

5.2 Preparation for installation

Before installation, make sure the following conditions are met:

- The actuator is not damaged.

Proceed as follows:

⇒ Lay out the necessary material and tools to have them ready during installation work.

Cover screws

Phillips screws are used to fasten the actuator housing cover. Use a POZIDRIV® PZ2 screwdriver to undo and tighten the screws.

5.3 Mounting the actuator

5.3.1 Construction with integrated yoke (form B)

For mounting on:

- Series V2001 (DN 15 to 50)
- Type 3214 (DN 65 to 100)
- Type 3260 (DN 65 to 80)
- Type 3260 (DN 100 to 150)

⇒ See Fig. 12.

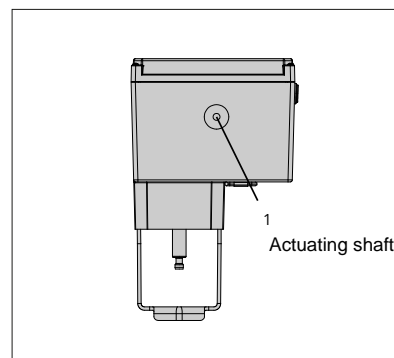

Fig. 10: Actuating shaft for manual override (version with integrated yoke)

1 Control axis

1. Remove protective covers and unscrew nut (6) from the valve.
2. **Actuator without fail-safe action:** Retract the actuator stem (3) (see Chapter 8.2.1).
Actuator with fail-safe action: Retract the actuator stem electrically in the MAN mode (see Chapter 8.2.3).
3. Place the actuator with yoke on the valve and fasten using nut (6, A/F 36).

Tightening torque	100 Nm
-------------------	--------

Installation

4. When the plug stem (5) fits closely onto the actuator stem (3), attach both stem connector clamps (4) and fasten with screws.



Fig. 11: For example, Type 3374-21 Electric Actuator, mounted on a Series V2001 Globe Valve

Types 3374-10/-11/-21/-31

Connection with yoke (form B)

Mounting on Series V2001 Valves (DN 15 to 50)

Type 3260, DN 65 to 150

Type 3214, DN 65 to 100

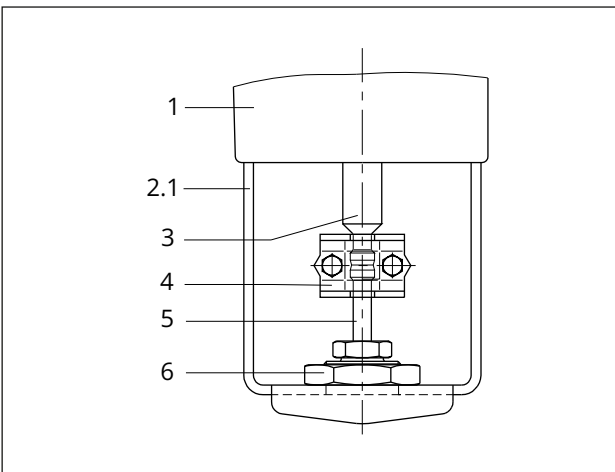

Fig. 12: Mounting - Version with integrated yoke

- 1 Actuator
- 2.1 Actuator yoke
- 3 Actuator stem
- 4 Stem connector
- 5 Plug stem
- 6 Nut

Mounting on Series V2001 Valves (DN 65 to 100)

⇒ See Fig. 13.

1. Remove protective covers.
2. **Actuator without fail-safe action:** Retract the actuator stem using the manual override (see Chapter 8.2.1).
Actuator with fail-safe action: Retract the actuator stem electrically in the MAN mode (see Chapter 8.2.3).
3. Place the actuator with yoke on the valve and fasten using the screws (11).

i Note

A spacer (see Chapter 17) is required to mount a Type 3323 Three-way Valve.

4. Extend the actuator stem until the actuator stem (3) rests on the plug stem (5).
5. Position the two stem connector clamps (see Fig. 14) from the V2001 mounting kit and tighten.

Types 3374-10/-11/-21/-31
Connection with yoke (form B)
 Mounting on Series V2001 Valves (DN 65 to 100)

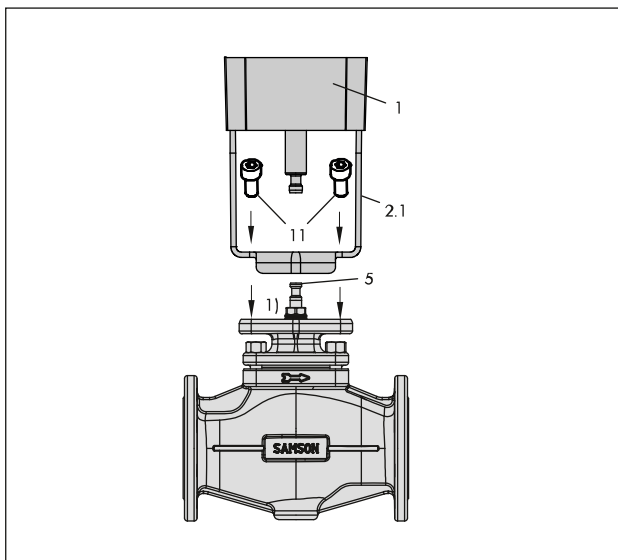

Fig. 13: Mounting · Version with actuator yoke and V2001 accessories

- 1 Actuator
- 2.1 Actuator yoke
- 3 Actuator stem
- 5 Plug stem
- 11 Screws
- 1) A spacer is required here to mount a Type 3323 Three-way Valve.

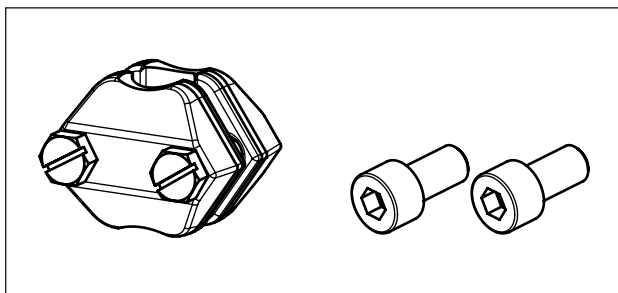

Fig. 14: Mounting kit V2001

i Note

The V2001 mounting kit is not included in the scope of delivery. It is available as an accessory (see Chapter 17.1).

5.3.2 Construction with ring nut (form A)

For mounting on:

- Series 240
- Series 250 (M30x1.5)
- Type 3214 balanced by a bellows (DN 125 to 250)
- Type 3260 (DN 65 to 100)
- Type 3260 (DN 100 to 150)

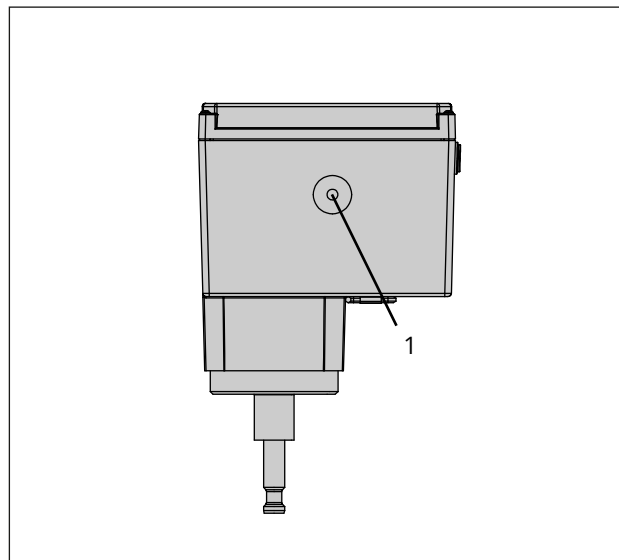

Fig. 15: Actuating shaft for manual override (version with ring nut)

- 1 Control axis

Mounting on Series 240 and 250 Valves

⇒ See Fig. 16 (Series 240).

1. Push the plug stem (5) down to close the valve.
2. Turn the stem connector nut (8) until the dimension x measures 75 mm (DN 100 and larger: 90 mm) from the top of the yoke to the middle of the stem connector nut (8). Lock this position with the lock nut (9).
3. **Actuator without fail-safe action:**
 Retract actuator stem (3) (see Chapter 8.2.1).
Actuator with fail-safe action:
 Retract the actuator stem electrically in the MAN mode (see Chapter 8.2.3).
4. Place actuator on the valve bonnet (2.3) and secure using the ring nut (7).
5. When the stem connector nut (8) rests on the actuator stem (3), attach both stem connector clamps (4) and fasten with screws.

Installation

Tightening torque	150 Nm
-------------------	--------

6. Move actuator stem (3) to the end position (valve closed) as described in Chapter 8.2.1.
7. Align travel indicator scale (10) with the middle of the stem connector (4) and screw tight.

Types 3374-15, -17, -25, -26, -27, -35, -36 Connection with ring nut (form A)

Mounting on Series 240 Valves:

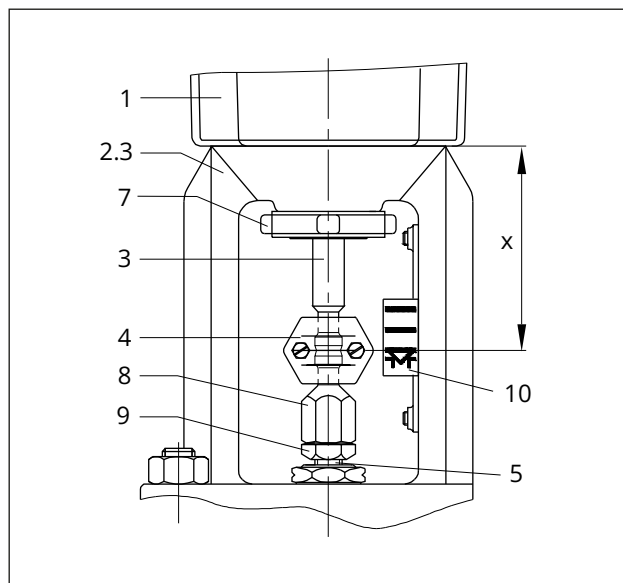

Fig. 16: Mounting on Series 240 Valves

- | | |
|-----|------------------------|
| 1 | Actuator |
| 2.3 | Bonnet |
| 3 | Actuator stem |
| 4 | Stem connector |
| 5 | Plug stem |
| 7 | Ring nut |
| 8 | Stem connector nut |
| 9 | Lock nut |
| 10 | Travel indicator scale |

Mounting on Type 3214 Valve (DN 125 to 250)

⇒ See Fig. 17.

1. Actuator without fail-safe action:

Retract actuator stem (3) (see Chapter 8.2.1).

Actuator with fail-safe action:

Retract the actuator stem electrically in the MAN mode (see Chapter 8.2.3).

2. Place actuator on the valve and secure using the ring nut (7). If necessary, retract the actuator stem slightly beforehand.
3. When the stem connector nut (5) rests on the actuator stem (3), attach both stem connector clamps (4) and fasten with screws.

Tightening torque	150 Nm
-------------------	--------

4. Move actuator stem (3) to the end position (valve closed) as described in Chapter 8.2.1.
5. Align travel indicator scale (10) with the middle of the stem connector (4) and screw tight.

Types 3374-15, -27
Connection with ring nut (form A)
 Mounting on Type 3214 (DN 125 to 250), balanced by a bellows

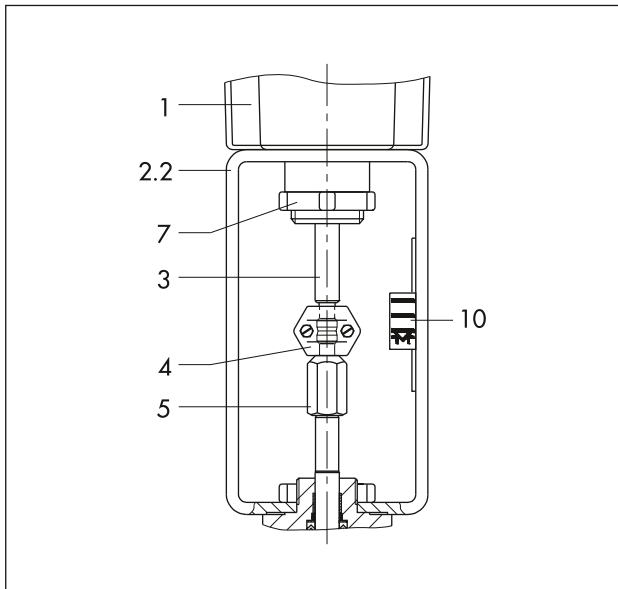

Fig. 17: Mounting on Type 3214

- 1 Actuator
- 2.2 Valve yoke
- 3 Actuator stem
- 4 Stem connector
- 5 Plug stem
- 7 Ring nut
- 10 Travel indicator scale

Mounting on Type 3260 (DN 65 to 150) and Type 3214 (DN 125 to 250), valves balanced by a diaphragm

⇒ See Fig. 18.

1. Actuator without fail-safe action:

Retract actuator stem as described in Chapter 8.2.1.

Actuator with fail-safe action:

Retract the actuator stem electrically in the MAN mode (see Chapter 8.2.3).

Retract actuator stem as described in Chapter 8.2.1.

2. Place the additional yoke on the valve and tighten.
3. Place actuator on the additional yoke and fasten using hex nut (2).
4. When the stem connector nut (5) rests on the actuator stem (3), attach both stem connector clamps (4) and fasten with screws.

Tightening torque	150 Nm
-------------------	--------

5. Move actuator stem (3) to the end position (valve closed) as described in Chapter 8.

Types 3374-15, -27
Connection with ring nut (form A)

Attachment to
 Type 3260 (DN 65 to 150) and Type 3214 (DN 125 to 250), valves balanced by a diaphragm

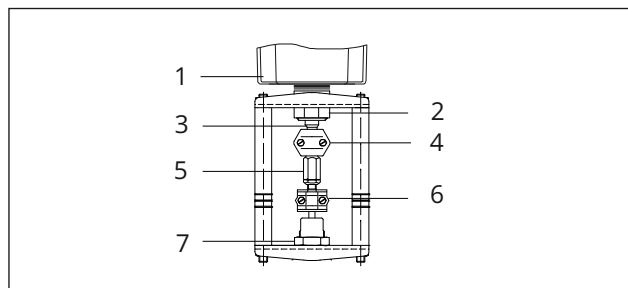

Fig. 18: Mounting on Type 3260 Valve (DN 65 to 150) and Type 3214 (DN 125 to 250), valves balanced by a diaphragm

- 1 Actuator
- 2 Hex nut
- 3 Actuator stem
- 4 Stem connector
- 5 Stem connector nut
- 6 Stem connector
- 7 Hex nut

5.4 Installing additional equipment

⚠ DANGER

Risk of fatal injury due to electric shock.

- ⇒ Before installing electrical accessories, switch off the supply voltage and protect it against unintentional reconnection.
- ⇒ Disconnect the signal lines.

5.4.1 Retrofitting limit contacts

To install the mechanical limit contacts, the following retrofit kits are required depending on the equipment:

- Mechanical limit contacts (see Fig. 19)

NOTICE

Risk of damage to the connecting cable due to incorrect handling.

- ⇒ Actuator version with three-key operation: make sure that the connecting cable between the housing cover and actuator board is not damaged when removing the housing cover.
- ⇒ Fasten the housing cover to the housing before performing work on the actuator.

Note

To undo the screws on the housing cover, use a POZIDRIV® PZ2 screwdriver to get enough hold on the screw heads.

Note

The contact cams (19) are ready-mounted to the cam holder (20) and the retaining rings (9) to form the contact cam unit (21) (see Fig. 21).

Tip

SAMSON recommends applying a small amount of lubricant (e.g. Vaseline) to the spindles on the gear faces and to the sides of the cogs.

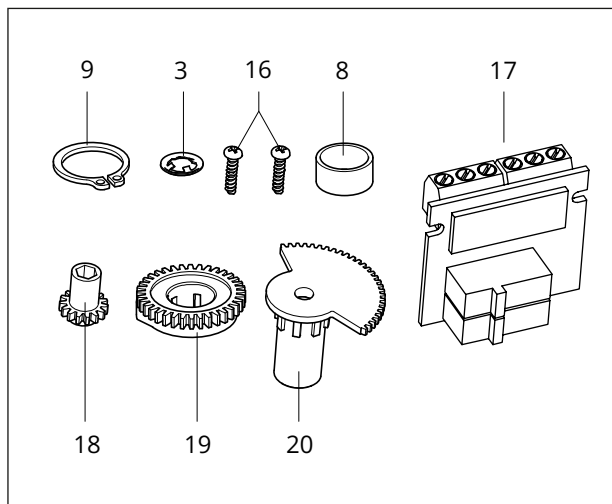

Fig. 19: Mechanical limit contacts · Retrofit kit

- 3 Serrated ring
- 8 Spacer
- 9 Retaining ring
- 16 Screw (WN 1412)
- 17 Terminal board
- 18 Adjustment gear
- 19 Contact cam
- 20 Cam holder

1. Undo screws on housing cover and remove the housing cover from the actuator.
2. Move the actuator stem to the end position depending on the fail-safe action "Actuator stem extends" or "Actuator stem retracts" (see Chapter 8).
3. Remove serrated ring and shim from spindle (11.2).
4. Slide adjustment gears (18) onto their spindles and fasten with one screw (16) each. Check whether the adjustment gears can be turned easily. Slightly loosen the screw, if necessary.
5. Turn contact cams (19) on the cam holder (20) as illustrated in Fig. 21 corresponding with the position of the actuator stem.
6. Slide the spacer (8) onto the spindle (11.2). Make sure that the long wire of the tension spring rests on the spacer and on the intermediate gear.
7. Slide the contact cam unit (20) onto the spindle corresponding with the position of the actuator stem as illustrated in Fig. 20. Make sure that the outermost cog of the contact cam unit engages in the gearwheel of the intermediate gear (1). In addition, the adjustment gears (18) must en-

gage properly in the corresponding gears of the contact cam unit (20).

8. Secure the contact cam unit (21) and intermediate gear (1) with the serrated ring (3); push down the serrated ring as far as it will go.
9. Position the terminal board (17) at the base of the support at a 45° angle (approx.) with the switches pointing towards the gears. Swivel the upper end of the terminal board towards the gears until the board is in a vertical position and properly engaged in the support.
10. Adjust limit contacts as described in Chapter 7.
11. Replace the housing cover. Briefly turn the fastening screws counterclockwise with a screwdriver to center them. Then fasten down the cover by tightening the screws.

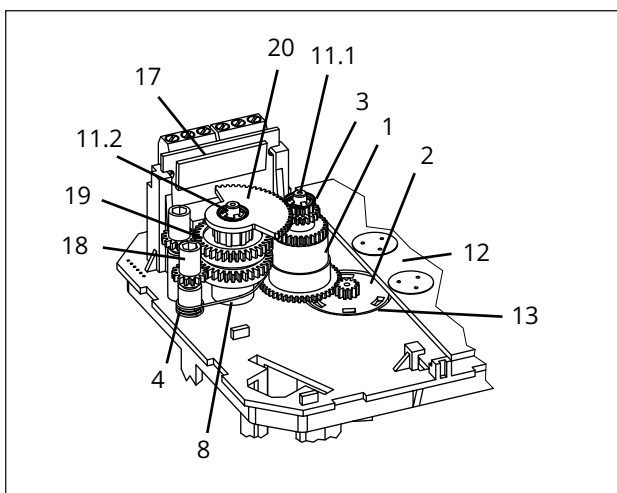

Fig. 20: Inside view of Type 3374 Actuator

- 1 Intermediate gear
- 2 Spindle gear
- 3 Serrated ring
- 4 Tension spring
- 8 Spacer
- 11.1 Spindle 1
- 11.2 Spindle 2
- 12 Actuator board
- 13 Bearing sleeve
- 17 Terminal board
- 18 Adjustment gear
- 19 Contact cam
- 20 Cam holder

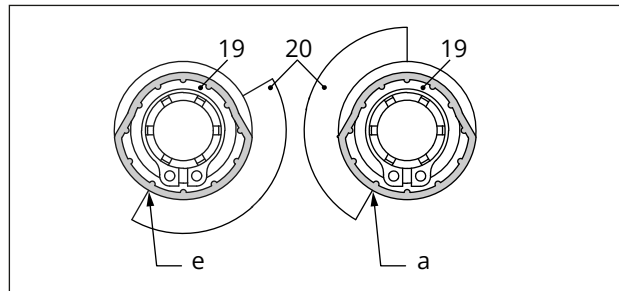

Fig. 21: Contact cam and switch carrier

- e Actuator stem retracted
- a Actuator stem extended
- 19 Contact cam
- 20 Switch carrier

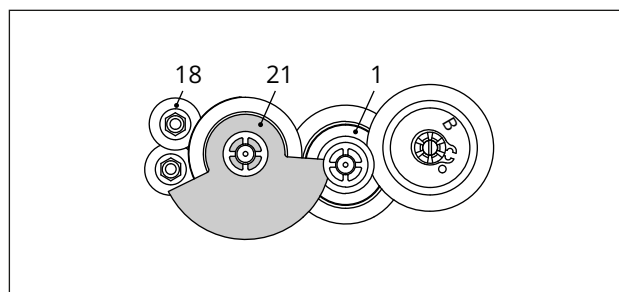

Fig. 22: Contact cam unit with actuator stem retracted

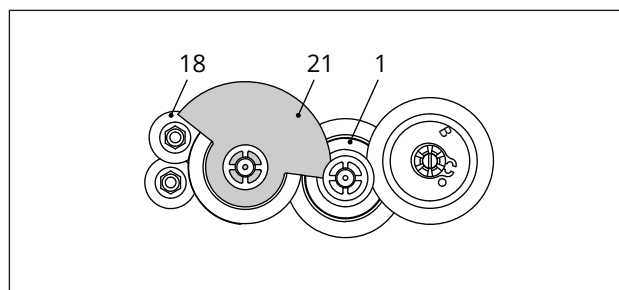

Fig. 23: Contact cam unit with actuator stem extended

- 1 Intermediate gear
- 18 Adjustment gear
- 21 Contact cam

Installation

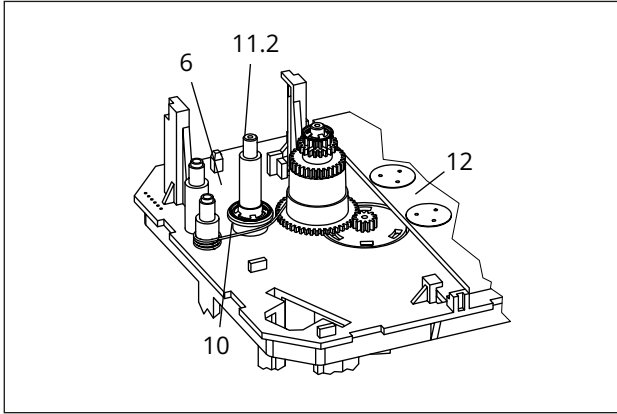

Fig. 24: Inside view · Type 3374 Actuator with resistance transmitters

- 6 Serrated ring
- 10 Shim
- 11.2 Spindle 2
- 12 Actuator board

5.4.2 Retrofitting electronic limit contacts

⚠ DANGER

Risk of fatal injury due to electric shock.

- ⇒ Before installing electrical accessories, switch off the supply voltage and protect it against unintentional reconnection.
- ⇒ Disconnect the signal lines.

ⓘ NOTICE

Risk of damage to the connecting cable due to incorrect handling.

- ⇒ Actuator version with three-key operation: make sure that the connecting cable between the housing cover and actuator board is not damaged when removing the housing cover.
- ⇒ Fasten the housing cover to the housing before performing work on the actuator.

i Note

To undo the screws on the housing cover, use a POZIDRIV® PZ2 screwdriver to get enough hold on the screw heads.

To install the mechanical limit contacts, the following retrofit kits are required depending on the equipment:

- Electronic limit contacts
1. Undo screws on housing cover and remove the housing cover from the actuator.
 2. Connect the connector on the connecting cable to the plug-in location intended for it on the board.
 3. Position the terminal board (17, see Fig. 19) at the base of the support at an approximate 45° angle with the relay pointing towards the edge of the intermediate board. Swivel the upper end of the terminal board until the board is properly engaged.
 4. Adjust limit contacts as described in Chapter 7.
 5. Replace the housing cover. Briefly turn the fastening screws counterclockwise with a screwdriver to center them. Then fasten down the cover by tightening the screws.

5.4.3 Retrofitting RS-485 module

To install the RS-485 module for Modbus RTU communication, the following retrofit kit is required:

- RS-485 module
1. Unscrew screws on housing cover and take the cover off the actuator.
 2. Disconnect the supply voltage and protect it against unintentional reconnection.
 3. Insert the four spacers into the holes intended for them in the actuator board.
 4. Place the RS-485 module with the connector side facing downward onto the spacers.
 - ⇒ Guide the pins from the top into the socket on the board.
 5. Perform the wiring as described in Chapter 5.
 6. Set up Modbus communication (see Chapter 7).

5.5 Electrical connection

⚠ DANGER

Risk of fatal injury due to electric shock.

- ⇒ Upon installation of the electric cables, you are required to observe the regulations concerning low-voltage installations according to DIN VDE 0100 as well as the technical connection requirements of your local energy supplier.
- ⇒ For electrical installation, observe the relevant electrotechnical regulations and the accident prevention regulations that apply in the country of use. In Germany, these are the VDE regulations and the accident prevention regulations of the employers' liability insurance.
- ⇒ Before connecting wiring, performing any work on the device or opening the device, disconnect the supply voltage and protect it against unintentional reconnection.
- ⇒ Use a suitable voltage supply which does not allow any dangerous voltage to reach the device in normal operation or in the event of a malfunction in the system or any other system parts.
- ⇒ Only perform the electrical connection after disconnecting the supply voltage. Make sure the supply voltage cannot be reconnected unintentionally.
- ⇒ Use approved cable glands with cable grip at the cable entry.
- ⇒ Only use protective equipment that can be protected against unintentional reconnection of the power supply.
- ⇒ Do not remove any covers to perform adjustment work on live parts.

⚠ DANGER

Touching exposed wire ends can cause fatal injury.

Appropriate mechanical fixtures must be mounted in front of the terminals to ensure that the connected wires cannot become loose or be pulled out unintentionally.

- ⇒ Take suitable precautions to prevent wires from disconnecting.

ⓘ NOTICE

Risk of actuator damage due to incorrect wiring of the binary inputs.

- ⇒ Wire the binary inputs as floating contacts.

ⓘ NOTICE

Risk of actuator malfunction due to the removal of the potentiometer gear or a change in its position.

After connecting the supply voltage, the actuator is ready for use. Tampering with the mechanical parts inside the actuator will impair the functioning of the actuator.

- ⇒ Do not tamper with mechanical parts.

ⓘ NOTICE

Incorrect routing of wires can cause the touch voltage to exceed the permissible limit.

- ⇒ Install the power supply cable and the signal cable separately and leave sufficient space between them.

i Note

A maximum of three cable glands can be mounted on the housing for cable entry.

- ⇒ Connect the wiring according to the following wiring plans.
- ⇒ Guide the cables to the spring-cage terminals from the top (see Table 5).

i Note

The permissible outside diameter of the lines used is 6 to 12 mm.

Table 5: Cables and stranded wires that can be used

Cable	Conductor cross-section
Single-wire H05(07) V-U ¹⁾	0.2 to 1.5 mm ²
Fine-wire H05(07) V-K ¹⁾	0.2 to 1.5 mm ²
With wire ferrule according to DIN 46228-1	0.25 to 1.5 mm ²
With wire ferrule with collar according to DIN 46228-4	0.25 to 0.75 mm ²

¹⁾ Length of insulation to be stripped off the conductor ends: 8 mm

Installation

5.5.1 Electrical connection (standard version)

1. Undo screws on housing cover and remove the housing cover from the actuator.
2. Connect the wiring according to the following wiring plans.
3. Guide the cables to the spring-cage terminals from the top (see Table 5).
4. Connect binary inputs using floating contacts.

i Note

After connecting the supply voltage on starting up the actuator for the first time, the start screen and the error reading E00 RUNT (no initialization performed) appear in alternating sequence (see Chapter 6).

i Note

The function of the inputs depends on how the actuator is configured. Inputs that have not been configured do not have any effect.

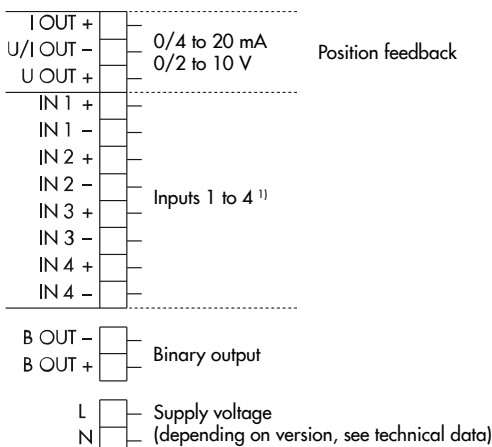

¹⁾ The assignment of inputs 1 to 4 is shown in the following wiring plans and depends on the selected application.

Fig. 25: Electrical connection

- 1 Position feedback
- 2 Inputs 1 to 4
The assignment of the inputs is shown in the following wiring diagrams and depends on the application that has been selected.
- 3 Binary output
- 4 Supply voltage (depending on version, see Technical data)

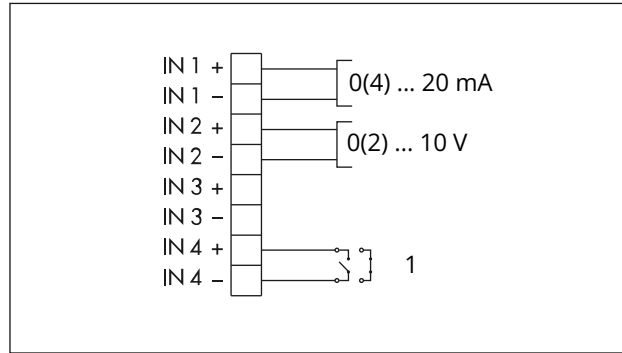

Fig. 26: Terminal assignment for 'Positioner' application

- 1 Binary input; function configurable in c11 and c12

► **Wire the input free of voltage.**

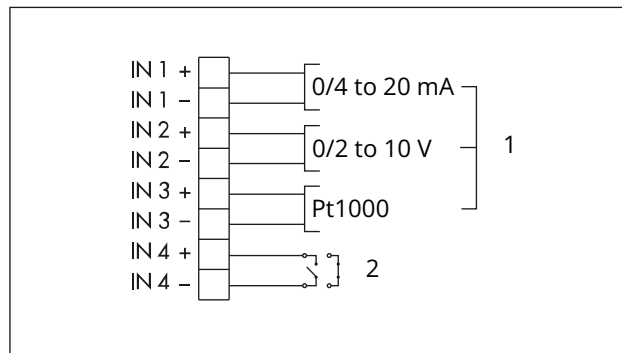

Fig. 27: Terminal assignment for 'PID controller' application

- 1 Controlled variable selection
- 2 Binary input; function configurable in c11 and c12

► **Wire the input free of voltage.**

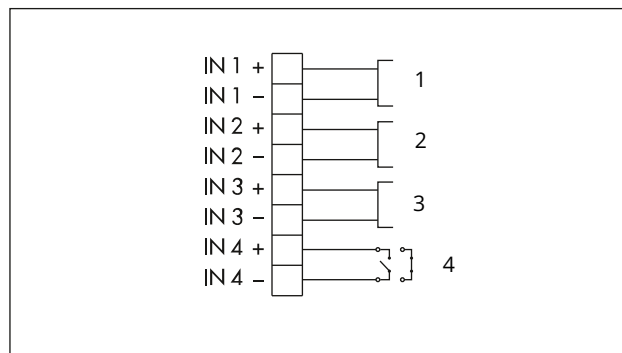

Fig. 28: Terminal assignment for 'PID controller' application · Temperature control

- 1 Pt 1000 (readout only possible using Modbus)
- 2 Pt 1000 (readout only possible using Modbus)
- 3 Pt1000 (controlled variable)
- 4 Binary input; function configurable in c11 and c12

► **Wire the input free of voltage.**

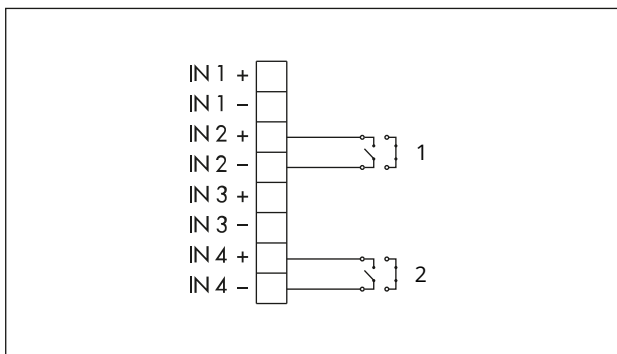

Fig. 29: Terminal assignment for 'Two-step mode' application

- 1 On/off control
- 2 Binary input; function configurable in c11 and c12
- **Wire the input free of voltage.**

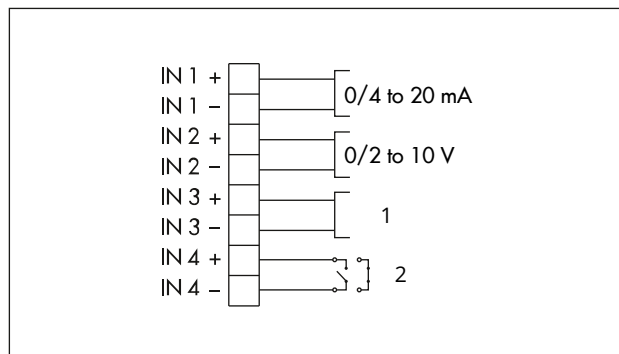

Fig. 32: Terminal assignment for 'Temperature closed-loop control upon input signal failure' application

- 1 Pt1000 (controlled variable)
- 2 Binary input; function configurable in c11 and c12
- **Wire the input free of voltage.**

Options:

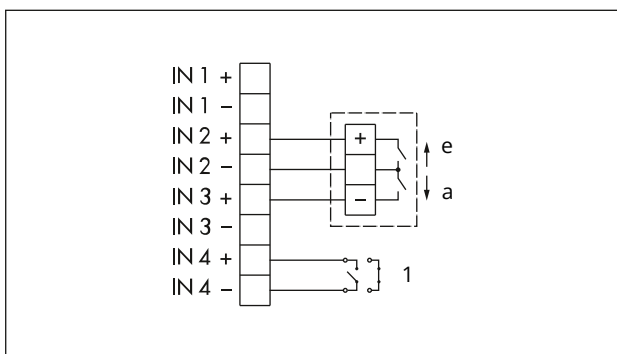

Fig. 30: Terminal assignment for 'Three-step mode' application with three-wire connection

- e Retracts
- a Extends
- 1 Binary input; function configurable in c11 and c12
- **Wire inputs free of voltage.**

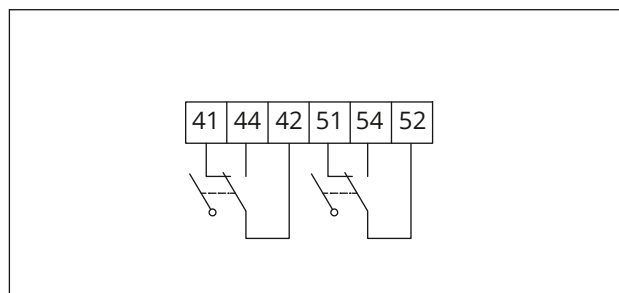

Fig. 33: Mechanical limit contacts

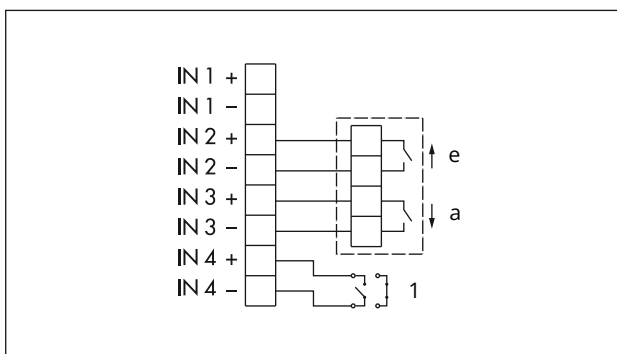

Fig. 31: Terminal assignment for 'Three-step mode' application with four-wire connection

- e Retracts
- a Extends
- 1 Binary input; function configurable in c11 and c12
- **Wire inputs free of voltage.**

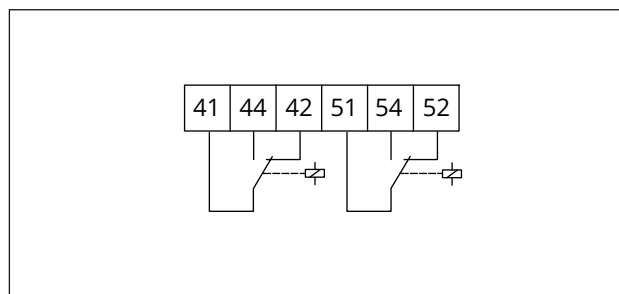

Fig. 34: Electronic limit contacts

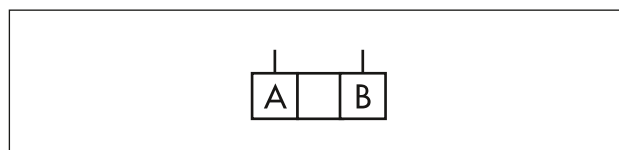

Fig. 35: RS-485 interface

Installation

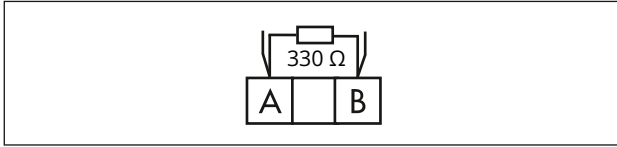

Fig. 36: RS-485 interface with external bus termination

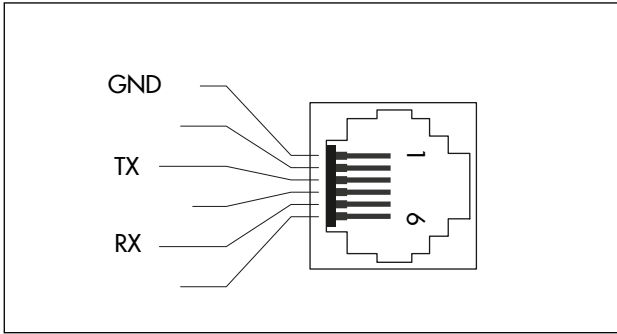

Fig. 37: Assignment of the RJ-12 jack

⇒ Replace the housing cover. Briefly turn the fastening screws counterclockwise with a screwdriver to center them. Then fasten down the cover by tightening the screws.

5.5.2 Electrical connection for special version with three-key operation

Perform electrical connection for the special version of Type 3374 with three-key operation as follows:

⇒ See Fig. 38.

1. Unthread the four fastening screws of the housing cover. Lift the housing cover off the actuator.

⇒ Make sure the connecting cables (1) of the housing cover are not damaged by tensile load.

2. Move the housing cover to the position as shown in Fig. 38.

3. Place on cover. Briefly turn the screw (2) counterclockwise to center it. Tighten it slightly.

⇒ Make sure that the screw is not screwed all the way into the thread. Otherwise, the cover seal may become damaged.

4. Perform the electrical connection according to Chapter 5.5.1.
5. Loosen the screw (2), while holding the housing cover to ensure the connecting cables (1) of the housing cover do not get damaged by tensile load.
6. Place the housing cover on the housing and route the connecting lines in the housing as shown in Fig. 38.
⇒ Make sure the connecting cables of the housing cover do not get jammed.
7. Briefly turn the fastening screws counterclockwise with a screwdriver to center them. Then fasten down the cover by tightening the screws.

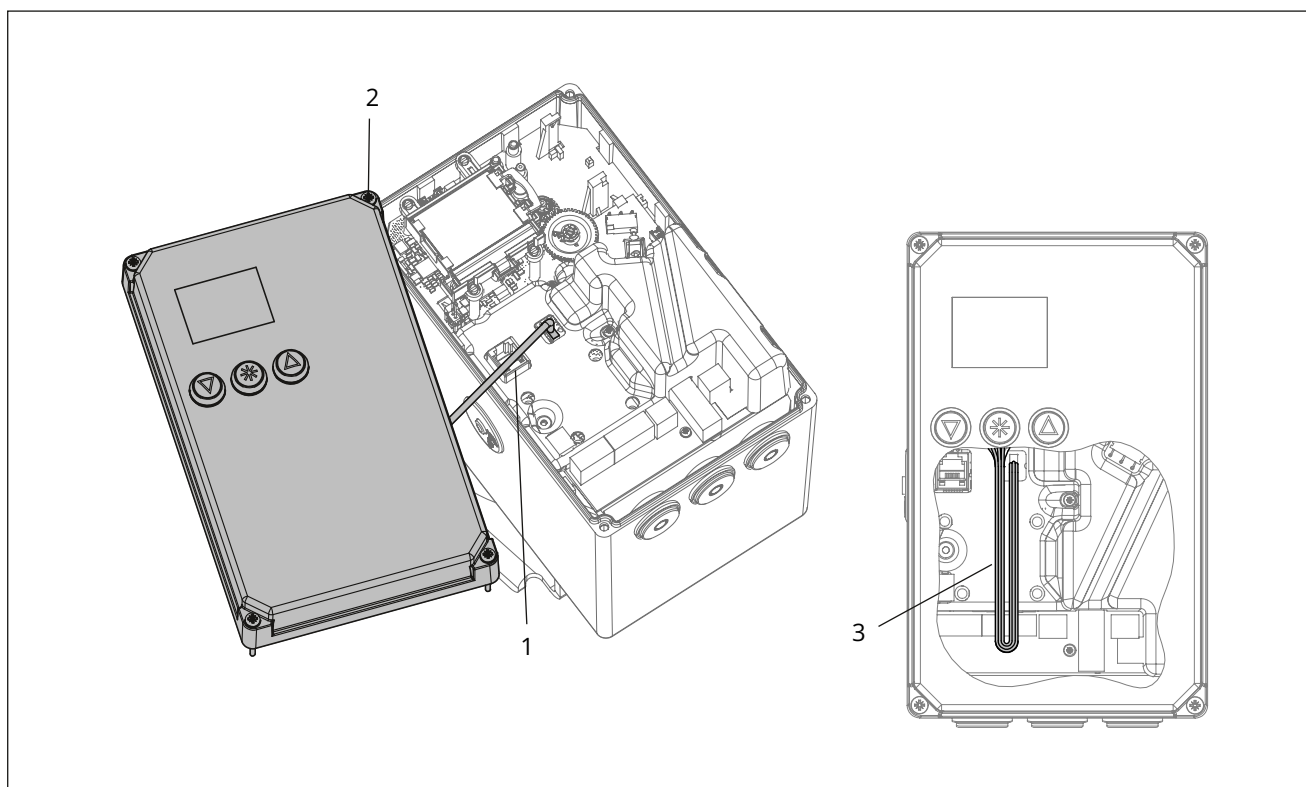

Fig. 38: Connection for special version with three-key operation

- 1 Connecting lines with the housing cover removed
- 2 Screw mounting
- 3 Connecting lines with the housing cover attached

NOTICE

Risk of damage to the connecting cable due to incorrect handling.

- ⇒ *Actuator version with three-key operation: make sure that the connecting cable between the housing cover and actuator board is not damaged when removing the housing cover.*
- ⇒ *Fasten the housing cover to the housing before performing work on the actuator.*

6 Operation

i Note

The housing cover must be removed before performing changes to settings at the electric actuator. After work is completed, the housing cover must be reattached and fastened.

6.1 Device overview and operating controls

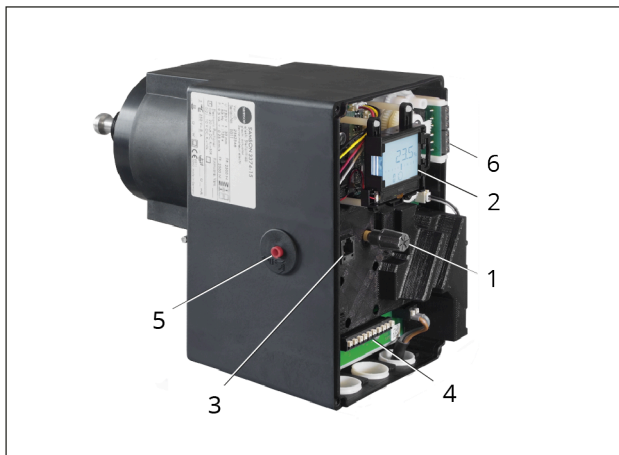

Fig. 39: Operating controls with the housing cover removed

- 1 Rotary pushbutton
- 2 Display
- 3 Serial interface
- 4 Terminals
- 5 Actuating shaft for mechanical manual override
- 6 Terminal board for limit contacts

6.1.1 Display

After applying the supply voltage, the current firmware is displayed for two seconds. Afterwards, the start screen appears.

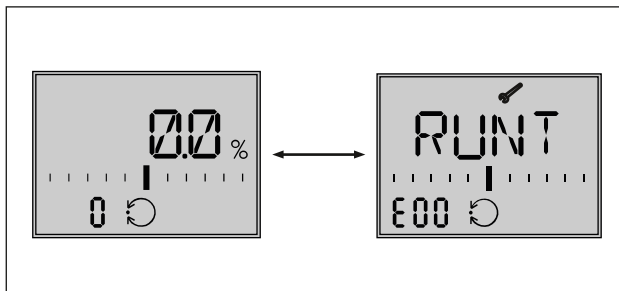











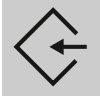



Fig. 40: Start screen after starting up the actuator for the first time

On starting up the actuator for the first time, the start screen and the error reading **E00** (no initialization performed) appear in alternating sequence.

Start screen

The start screen depends on the selected application (see Chapter 7). On starting up the actuator for the first time and after loading default settings, the positioner application (POSI) is automatically selected.



Table 6: Display icons

Operating mode		Automatic mode
		Manual mode
Bar graph The bars indicate the set point deviation that depends on the sign (+/-) and the value.	 One bar element appears per 1 % set point deviation. Example:  Bar graph indicates a +3 % set point deviation. A maximum of five bar elements can appear on each side. Five bar elements indicate a set point deviation ≥ 5 %.	
Status messages These icons indicate that an error has occurred.		Failure
		Maintenance demanded
Binary input/output active Code in bottom left-hand corner of the display		Code 0 on the display, binary input active
		Code 0 on the display, binary output active
		Code 0 on the display, binary input/output active
Enable configuration		Indicates that the parameters in the configuration and service levels have been enabled for configuration.
Limit contacts		Display reading 1
		Display reading 2 Indicates that the actuator stem position has fallen below or exceeded the switching point of the electronic limit contact.
Default setting		When the scale of the bar graph is not visible and only one bar element either side of the center is visible, this means the indicated parameter is the same as the default setting.
mA unit		The icon indicates the mA unit in conjunction with a reading.

Operation

6.1.2 Rotary pushbutton

The operating controls are located underneath the housing cover (see Chapter 6.1). The settings are changed using the rotary pushbutton.

Turn : Select/change codes and values
Press : Confirm setting/change



NOTICE

The process will be directly affected since changed parameters are immediately effective.

⇒ First check any changes made to parameters before confirming them by pressing the rotary pushbutton.



Note

On selecting the PID application during configuration, the adjusted set point is displayed as long as the  rotary pushbutton remains pressed. In this case, it is not possible to change the set point by turning the rotary pushbutton.

Press : Select/change codes and values
Press : Confirm setting/change
Press : Select/change codes and values (reduce value)

The operation and setting of the Type 3374 Actuator is described in these Mounting and Operating Instructions based on the version with rotary pushbutton. Pressing the arrow keys corresponds to turning the rotary pushbutton and the enter key corresponds to pressing the rotary pushbutton of the standard actuator version.

Note

On selecting the PID or POSF application during configuration, the adjusted set point is displayed as long as the  key remains pressed. The set point can be changed by pressing the  or  keys.

The key number does not need to be entered beforehand in this case.

6.1.3 Three-key operation

In the special version with three-key operation, the actuator is operated using three keys on the cover.

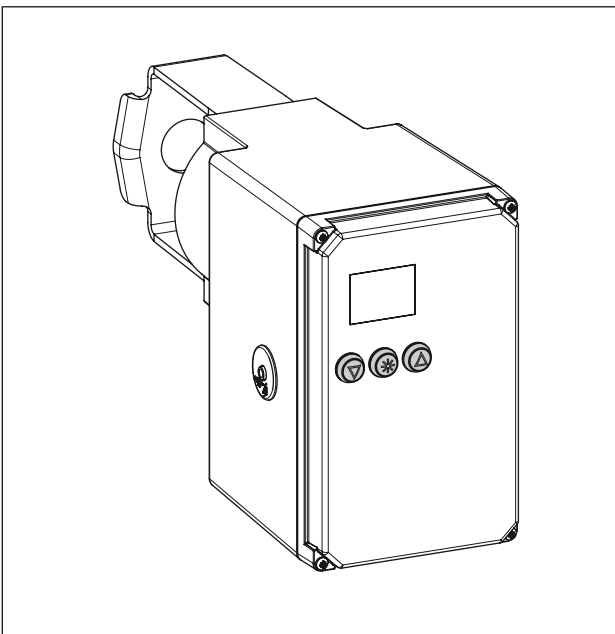

Fig. 41: Special version with three-key operation

- 1 Connecting line with the housing cover removed
- 2 Screw mounting
- 3 Connecting lines with the housing cover attached

7 Start-up and configuration

7.1 Initializing the actuator

⚠ WARNING

Risk of injury due to the actuator stem extending or retracting.

⇒ Do not touch or block the actuator stem.

ⓘ NOTICE

The process is disturbed by the movement of the actuator stem.

⇒ Do not perform the initialization while the process is running. First isolate the plant by closing the shut-off valves.

ⓘ NOTICE

Risk of actuator malfunction due to the removal of the potentiometer gear or a change in its position.

After connecting the supply voltage, the actuator is ready for use. Tampering with the mechanical parts inside the actuator will impair the functioning of the actuator.

⇒ Do not tamper with mechanical parts.

The initialization is performed in Code 5. During initialization, the actuator stem moves from its current position to the 100 % end position. Starting from the 100 % end position, the actuator stem moves to the 0 % end position.

i Note

Initialization is not possible in manual mode.

i Note

The 0 % and 100 % end positions depend on the direction of action used (see Chapter 16).

⇒ Before initialization, mount the actuator on the valve as described in Chapter 5.

⇒ Set the automatic mode (see Chapter 8).

Code	Description	Default	Adjustment range
5	Start initialization.		INI

How to proceed:

1. Turn **⊕** (when the start screen appears) to select Code 5.
2. Press **⊕**. **INI** blinks on the display.

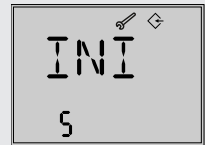

3. Press **⊕**. **INI** and the **⊕** icon appear. Initialization starts.

Initialization can be canceled at all times by selecting ESC.

After the initialization has been successfully completed, **OK** is displayed.



4. Press **⊕** to confirm.

7.2 Configuring the actuator

⇒ Additional configuration instructions (see Chapter 16)

⇒ Select Code 10 (configuration level CO) and press **⊕** to confirm.

i Note

The key number does not need to be entered in the delivered state.

How to proceed when the key number is active:

1. Turn **⊕** (when the start screen appears) to select Code 9.
2. Press **⊕** to confirm.



Display: Input field for key number

3. Press **⊕** to activate the input field.



Start-up and configuration

4. Turn \odot to enter the service key number.

The service key number can be found at the end of these mounting and operating instructions.



5. Press \odot to confirm.

The \diamond icon indicates that the configuration level is enabled to change the parameter.



After entering the key number, the corresponding levels are enabled for five minutes (indicated by \diamond icon). The levels are automatically locked again after five minutes.

The levels can also be locked again: select Code 9. **OFF** is displayed. After confirming it by pressing \odot , the icon disappears.

i Note

Codes that can be configured in the configuration level depend on which application has been selected (see Chapter 16).

7.2.1 Fast configuration level

Code 8 opens the fast configuration level. This allows the selection of settings that include several parameter configurations.

Code	Description	Reading	Adjustment range
8	Fast configuration	FCO	In, Out, dir,

Code	Description	Reading
In	Input signal 0 to 20 mA	0-20
	Input signal 4 to 20 mA	4-20
	Input signal 0 to 10 V	0-10
	Input signal 2 to 10 V	2-10
Out	Position feedback signal 0 to 20 mA	0-20
	Position feedback signal 4 to 20 mA	4-20
	Position feedback signal 0 to 10 V	0-10
	Position feedback signal 2 to 10 V	0-10
dir	Direction of action: increasing/increasing	>>
	Direction of action: increasing/decreasing	<>

i Note

Only one setting can be selected for each range. Selected settings are marked on the display by dashes (see following section).

Open fast configuration level

1. Turn \odot (when the start screen appears) to select Code 8.

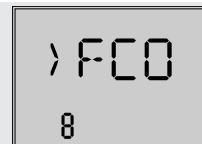

2. Press \odot . The first setting that can be selected appears.

Code **In**, input signal 0 to 20 mA

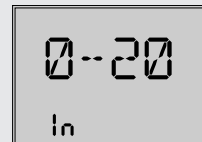

3. Press \odot and select the setting (indicated by the dashes).

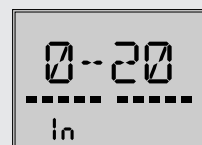

4. Turn \odot to open other selectable settings.

Example shown:

Code **dir**, direction of action increasing/increasing selected.



7.3 Selecting the application

The actuator's application can be selected from one of the following applications:

- Positioner (POSI, default setting)
- PID controller (PID)
- Two-step mode (2STP)
- Three-step mode (3STP)
- Temperature closed-loop control upon input signal failure (POSF)

⇒ Description of functions (see Chapter 16).

i Note

- Depending on the selected application, wire the terminals of the actuator as specified (see Chapter 5).
- Not all parameters and settings are shown when a certain application is selected.

Code	Description	Default	Adjustment range
6	Application	POSI	POSI (positioner) PID (PID controller) 2STP (two-step mode) 3STP (three-step mode) POSF (temperature closed-loop control upon input signal failure)

Positioner application (see Chapter 16 for description)

- ⇒ Set Code 6 to 'POSI'.
- ⇒ Perform the electrical connection according to Chapter 5.

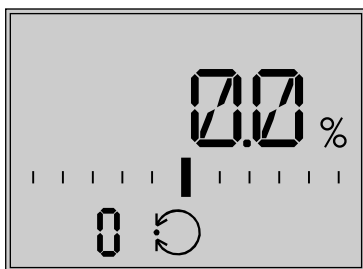

Fig. 42: Start screen with temperature closed-loop control upon input signal failure application (POSF) · Displayed reading: travel

PID controller application (see Chapter 16 for description)

- ⇒ Set Code 6 to 'PID'.
- ⇒ Perform the electrical connection according to Chapter 5.



Fig. 43: Start screen with PID controller application (PID) · Displayed reading: process variable

Two-step mode application (see Chapter 16 for description)

- ⇒ Set Code 6 to '2STP'.
- ⇒ Perform the electrical connection according to Chapter 5.

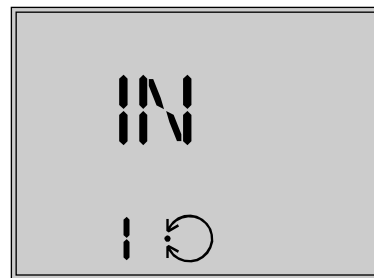

Fig. 44: Start screen with two-step mode application (2STP) · Displayed reading: state

Three-step mode application (see Chapter 16 for description)

- ⇒ Set Code 6 to '3STP'.
- ⇒ Perform the electrical connection according to Chapter 5.

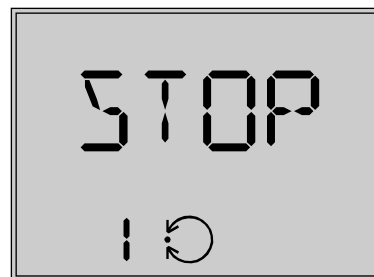

Fig. 45: Start screen with three-step mode application (3STP) · Displayed reading: state

Temperature closed-loop control upon input signal failure application (see Chapter 16 for description)

Start-up and configuration

- ⇒ Set Code 6 to 'POSF'.
- ⇒ Perform the electrical connection according to Chapter 5.

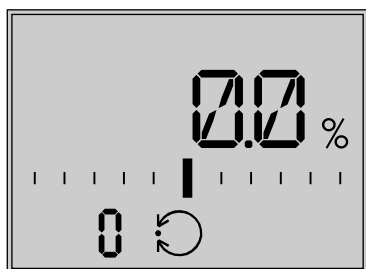

Fig. 46: Start screen with temperature closed-loop control upon input signal failure application (POSF) · Displayed reading: travel

i Note

The 0 to 10 V or 0 to 20 mA setting for the input signal is not possible in combination with this function. The lower value must be at least 0.5 V or 1 mA to ensure a signal failure can be detected.

7.4 Adjusting the limit contacts

i Note

To undo the screws on the housing cover, use a POZIDRIV® PZ2 screwdriver to get enough hold on the screw heads.

Mechanical limit contacts

1. Undo screws on housing cover and remove the housing cover from the actuator.
2. Connect supply voltage.
3. Move the actuator stem, using manual override or the 'manual level' operating mode, to the point at which the contact should react.
4. Use the 4 mm hex wrench to turn spindle of the adjustment gears (18) for the upper limit contact or for the lower limit contact until the associated contact cam on the cam holder (20) triggers the switch contact of the upper or lower microswitch on the terminal board (17).
5. Replace the housing cover. Briefly turn the fastening screws counterclockwise with a screwdriver to center them. Then fasten down the cover by tightening the screws.

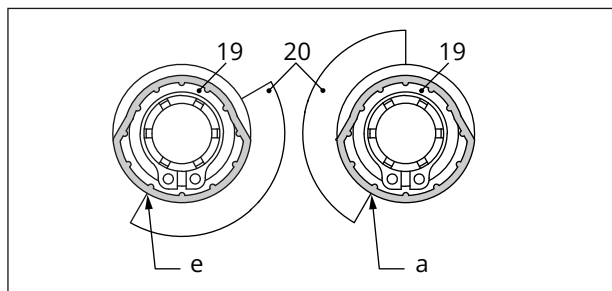

Fig. 47: Contact cam and switch carrier

- e Actuator stem retracted
- a Actuator stem extended
- 19 Contact cam
- 20 Switch carrier

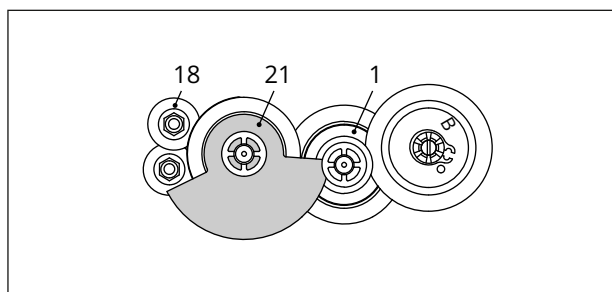

Fig. 48: Contact cam unit with actuator stem retracted

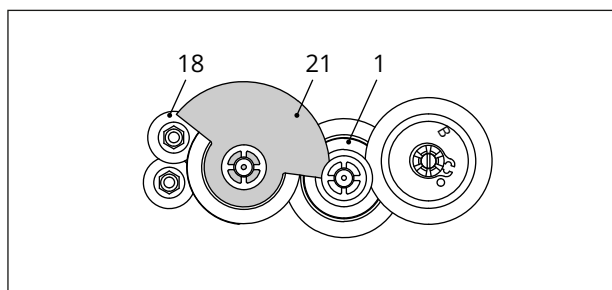

Fig. 49: Contact cam unit with actuator stem extended

- 1 Intermediate gear
- 18 Adjustment gear
- 21 Contact cam

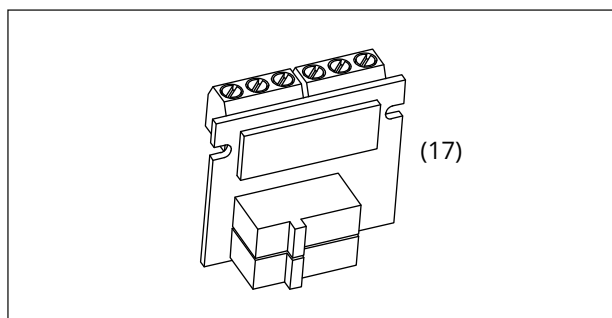

Fig. 50: Limit contact board (17)

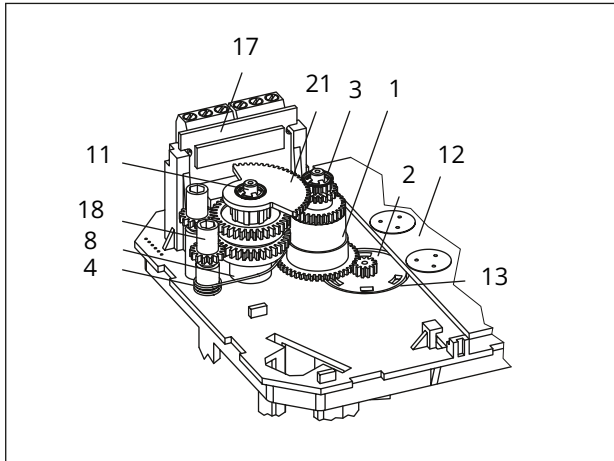

Fig. 51: Inside view · Retrofitting limit contacts

- 1 Intermediate gear
- 2 Spindle gear
- 3 Serrated ring
- 4 Tension spring
- 8 Spacer
- 11 Spindle
- 12 Actuator board
- 13 Bearing sleeve
- 17 Terminal board
- 18 Adjustment gear
- 21 Contact cam unit

Electronic limit contacts

The electronic limit contacts are adjusted at the operating controls of the actuator (see Chapter 16).

7.5 Setting up communication

In the communication level, details and possible settings for the actuator interfaces are displayed. Codes of the communication level have an 'A' prefix to identify them.

Activating and setting parameters

Activate the communication level

1. Turn ⌘ (when the start screen appears) to select Code 23. Code A51 is displayed.



Activating parameters

2. Turn ⌘ to select the required code.

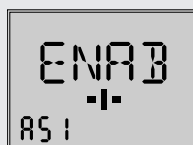

Setting parameters

3. Press ⌘. The reading blinks on the display. Turn ⌘ until the required setting is reached. Press ⌘ to confirm the setting.

Exiting the communication level

4. Turn ⌘ and select Code A00. Press ⌘ to exit communication level.

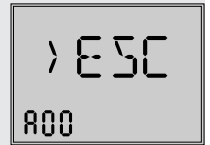

Serial interface

The actuator is fitted with an RS-232 serial interface. This allows communication with TROVIS-VIEW using SSP protocol and is ready for use by default.

7.6 Modbus RTU protocol

The electric actuator can be connected to a control station over Modbus and can be configured using TROVIS-VIEW. For this purpose, the actuator can be fitted with an RS-485 module. Various communications protocol (SSP or Modbus RTU slave) are used for various functions.

For Modbus RTU communication, the RS-485 module must be inserted into the actuator.

⇒ Excerpt from Modbus list (see Chapter 16).

Protocol

– **Setting: automatic**

The SSP and Modbus RTU protocols are automatically detected: the interface parameters are fixed internally to Baud rate 9600 bit/s, 8 data bits, no parity, 1 stop bit. The electric actuator can exchange data with TROVIS-VIEW or the control station without switching over. The station address and bus failure monitoring are adjustable.

– **Setting: Modbus RTU**

Communication is based on the Modbus RTU protocol. All interface parameters listed in Table 7 are adjustable.

Station address (Code A64)

The station number is used to identify the electric actuator for the Modbus RTU protocol.

Baud rate (Code A65)

The Baud rate is the transmission rate between the electric actuator and control station/computer. The Baud rate adjusted at the electric actuator must be the same as that in the control station. Otherwise, no communication is established.

Start-up and configuration

Stop bit and parity (Code A66)

The number of stop bits and the parity are set in Code A66. The parity is used to detect data transmission errors. The parity bit is added to the end of the string of data bits and the total value is made up from the data and parity bit.

Bus failure monitoring (Code A67)

The external manual level of the communication is monitored by the bus failure monitoring (timeout). After a bus failure is detected, automatic operation is reestablished. The time for the bus failure monitoring is adjustable. Set the value to **0** to deactivate bus failure monitoring.

Table 7: Modbus RTU parameter (setting in the communication level, see Chapter 8)

Code	Parameters	Display/select (select ESC to cancel)
Serial interface		
A51	Communication	ENAB (enabled) DISA (disabled)
Interface module		
A61	Communication	ENAB (enabled) DISA (disabled)
A62	Interface selection	485 (RS-485) USB (USB) ETH (Ethernet) NONE (without)
A63	Protocol	AUTO (automatic: SSP, Modbus) MODX (Modbus, adjustable)
Modbus interface module		
A64	Station address	1 to 247
A65	Baud rate (Baud)	1200 2400 4800 9600 192 (19200)
A66	Stop bits and parity	1SNP (1 stop bit, no parity) 1SEP (1 stop bit, even parity) 1SOP (1 stop bit, odd parity) 2SNP (2 stop bits, no parity)
A67	Bus failure monitoring (min) and timeout	0 to 99
A00	Exit level	ESC

8 Operation

After connecting the supply voltage, the actuator is ready for use.

8.1 Automatic mode

The behavior of the actuator in automatic mode depends on the application selected (see Chapter 3 for a description). A constant supply voltage must be applied to the actuator to allow it to operate (see Chapter 5).



8.1.1 Information level

In the information level, all the actuator data important for closed-loop operation are displayed. Codes of the information level have an 'i' prefix to identify them.

All the parameters of the information level are listed in the Appendix A (configuration instructions).

Activating parameters

Activating the information level

1. Turn  (when the start screen appears) to select Code 11.
2. Press  to activate the information level (i01 reading).

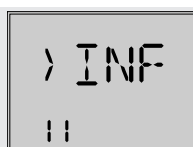

Activating parameters



3. Turn  to select the required code.

Example shown:

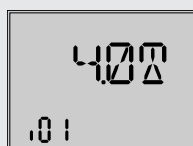
Code i01, Lower range value of input signal (the icon stands for the mA unit).



Exit information level

4. Turn  and select Code i00 (ESC).
5. Press  to exit information level.

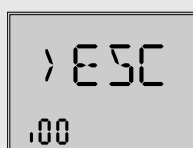

8.1.2 Operating level

The operating level is active while the actuator is in the automatic mode. In this level, important information on the operation is shown, the operating mode is selected and the initialization started. The other levels are accessible from the operating level. All the parameters of the operating level as well as fatal and EEPROM errors are listed in Chapter 9.

8.1.2.1 Selecting the operating mode

The actuator is normally in automatic mode indicated by the icon (displayed in Code 0 to 3). In automatic mode, the actuator stem follows the input signal according to the functions set in the configuration level. In manual mode, the actuator stem moves to the adjusted manual positioning value. An active manual mode is indicated in Code 0 by the  icon.

Code	Description	De-fault	Adjustment range
2	Operating mode	AUTO	AUTO (automatic mode) MAN (manual mode)
3	Positioning value (manual mode)	-	0.0 to 100.0 %

Note

The positioning value (manual mode) selected in Code 3 must be adjusted by the amount corresponding to at least half the dead band (adjustable in Code c67, see Chapter 7). Otherwise, the actuator stem will not move.

Example: Dead band adjusted to 2.0 % (default setting)

⇒ Adjust the positioning value (manual mode) by at least 1.0 % (for example, moving the actuator stem from 2.2 % to 3.2 %).

8.1.2.2 Determining the reading direction

The display contents can be turned by 180° in Code 4 to adapt the display reading to the actuator's mounting situation.

Code	Description	De-fault	Adjustment range
4	Reading direction	DISP	DISP , dSID

On changing the reading direction, the position of the icons and bar graph reading remains unchanged, while the segments for numbers, text as well as binary input and output are turned by 180°:

Operation

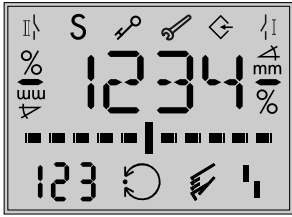

Default reading direction

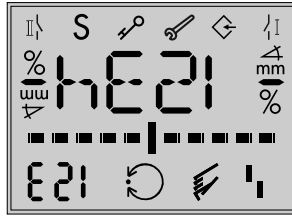

Reading direction turned by 180°

8.1.2.3 Switching on the backlight

The LCD backlight can permanently be switched on or off in Code c93.

Code	Description	Default	Adjustment range
c93	Backlight always on	NO	NO YES

i Note

- Regardless of the setting in Code c93, the backlight starts to blink whenever an error occurs (see Chapter 9).
- The display backlight can also be switched on and off by the binary input (see Chapter 7).

8.2 Manual mode

8.2.1 Mechanical override

To operate the manual override, place a 4 mm hex wrench on the red actuator shaft located at the side of the housing (see Fig. 52).

Turn the hex wrench clockwise to extend the actuator stem and turn it counterclockwise to retract the actuator stem. The hex wrench is included in the scope of delivery. It is attached to the bottom of the housing 1.

Optionally, the actuator can be delivered with handwheel for mechanical override.

i Note

A mechanical override is not possible for actuators with fail-safe action. These actuators do not have a hex wrench.

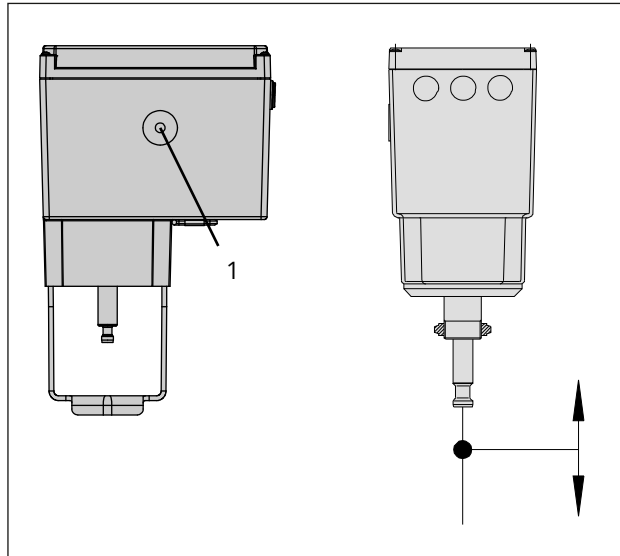

Fig. 52: Mechanical override

1 Control axis

8.2.2 Special version with handwheel

The additional handwheel is used for mechanical override in the special version of the electric actuator with handwheel (see Fig. 53).



Fig. 53: Special version with handwheel

1 (not in version with fail-safe action)

8.2.3 MAN mode

The electric actuator is normally in automatic mode indicated by the icon (displayed in Code 0 to 3). In MAN mode, the actuator stem moves to the adjusted manual positioning value. An active manual mode is indicated in Code 0 by the  icon. The positioning value can be adjusted in Code 3.

Code	Description	Default	Adjustment range
2	Operating mode	AUTO	AUTO (automatic mode) MAN (manual mode)
3	Positioning value (manual mode)	-	0.0 to 100.0 %

8.3 Operation using memory pen

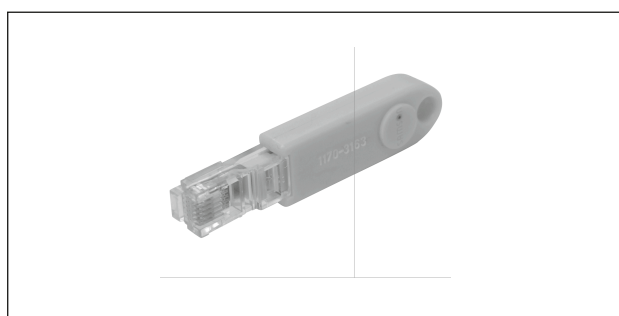

Fig. 54: Memory pen-64

⇒ ► EB 6661

The memory pen can be loaded with data configured in TROVIS-VIEW and the configuration data transferred to one or several devices of the same type and version. Additionally, the data from the device can be written to the memory pen. This allows the configuration data to be simply copied from one device and loaded onto other devices of the same type and version. The data logging function also allows operating data to be recorded.

The memory pen can be configured in TROVIS-VIEW. The following functions for the actuator can be selected:

- Read data from the memory pen
- Write data to the memory pen
- Time-controlled data logging
- Event-triggered data logging
- Command mode

Refer to the operating instructions for TROVIS-VIEW ► EB 6661 for details on how to configure the memory pen.

8.3.1 Memory and data logging function

1. Open the actuator cover.
2. Insert the memory pen into the serial interface of the actuator.

The actuator automatically recognizes the memory pen. The dialog for the memory pen is displayed. The function (command) selected in TROVIS-VIEW is represented by a code on the display (see Table 8).

3. Select the required action using the rotary push-button (depending on the function selected. See Table 8).

OK is displayed after data transmission is completed.

4. Remove memory pen after data transmission is completed.

The memory pen dialog ends. The start screen appears.

5. Close the actuator cover.

Table 8: Memory pen dialog

Code	Function	Action	Text
S02	Read data from the memory pen	Reading memory pen	READ
S03	Write data to the memory pen	Writing on memory pen	WRITE
S10	Time-controlled data logging	Data logging in progress	TLOG
S11	Event-triggered data logging	Data logging in progress	ELOG

Table 9: Memory pen error

Code	Error	Text
E51	Read error (memory pen)	ERD
E52	Write error (memory pen)	EWR
E53	Plausibility error	EPLA

8.3.2 Command mode

In closed-loop operation, the actuator stem can be moved to the top or bottom end position using the command pen regardless of the input signal. Data are written to the command pen using TROVIS-VIEW.

Possible settings:

Operation

- Retract actuator stem
- Extend actuator stem

These commands turn a memory pen into a command pen. After inserting the command pen into the actuator's interface, all functions running are ended and the command is executed. A command pen has priority over all functions.

i Note

The fail-safe action always has priority in actuators with fail-safe action. In this case the command function has a lower priority.

i Note

- A command pen remains active as long as it is inserted into the actuator's interface (even after a reset).
- Only one command at a time can be written to the memory pen and executed.

Using the command pen

1. Open the actuator cover.
2. Insert the command pen into the serial interface of the actuator.

The actuator automatically recognizes the command pen. The dialog for the command pen is displayed. The function (command) selected in TROVIS-VIEW is represented by a code on the display (see Table 10).

3. Remove command pen after the command has been executed.
- ⇒ The command pen dialog ends. The start screen appears.
4. Close the actuator cover again.

Table 10: Command pen dialog

Code	Error	Text
S21	Retract actuator stem	IN
S22	Extend actuator stem	OUT

8.4 Service mode

The service level contains detailed information on the actuator and its operating state. Additionally, various test functions can be performed in this level.

el. Codes in the diagnostic level have a 'd' prefix to identify them.

All the parameters of the service level are listed in the Appendix A (configuration instructions).

Activating the service level

1. Turn Ⓚ (when the start screen appears) to select Code 20.
2. Press Ⓚ to activate the service level (d01 reading).



Example shown: Start transit time measurement

3. Turn Ⓚ and select Code d61.
4. Press Ⓚ. The reading blinks on the display.
5. Press Ⓚ. The transit time measurement starts.



The transit time measurement can be canceled by selecting ESC.

Exiting the service level

6. Turn Ⓚ and select Code i00 (ESC).
7. Press Ⓚ to exit the service level.

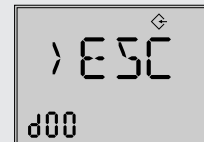

8.4.1 Zero calibration

⚠ WARNING

Risk of injury due to the actuator stem extending or retracting.

⇒ Do not touch or block the actuator stem.

ⓘ NOTICE

The process is disturbed by the movement of the actuator stem.

⇒ Do not perform zero calibration or initialization while the process is running. First isolate the plant by closing the shut-off valves.

The actuator stem moves to the 0 % end position. Following this, the actuator changes to closed-loop operation and moves the actuator stem to the position defined by the input signal.

Code	Description	Adjustment range
d51	Start zero calibration	ZER

Zero calibration can be canceled at all times by selecting **ESC**.

8.4.2 Initializing the actuator

⚠ WARNING

Risk of injury due to the actuator stem extending or retracting.

⇒ Do not touch or block the actuator stem.

ⓘ NOTICE

The process is disturbed by the movement of the actuator stem.

⇒ Do not perform zero calibration or initialization while the process is running. First isolate the plant by closing the shut-off valves.

The procedure is described in Chapter 7.

Code	Description	Adjustment range
d52	Start initialization	INI

Initialization can be canceled at all times by selecting **ESC**.

8.4.3 Restarting the actuator (reset)

The actuator can be restarted by performing a reset. Upon restart, the actuator goes into the operating mode previously set unless a different restart condition has been defined (see Chapter 7).

Code	Description	Adjustment range
d53	Perform reset	RES

8.4.4 Reset to default settings

All the parameters of the configuration level can be reset to their default settings.

Code	Description	Adjustment range
d54	Load default settings in actuator	DEF

8.4.5 Testing display

All the segments of the display are shown during the display test when a display functions properly.

The display test is performed by selecting Code d55 in the service level (Code 20).

Code	Description	Adjustment range
d55	Testing display	TEST

Activating the display test (service level/Code 20)

1. Turn **⊕** (when the start screen appears) to select Code d55.
2. Press **⊕** to start test.
All segments are shown.
3. Turn **⊕** to hide all segments (backlight remains switched on).
4. Press **⊕** to return to the **d55 TEST** reading.

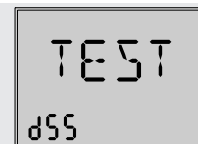

8.4.6 Measuring the transit time

⚠ WARNING

Risk of injury due to the actuator stem extending or retracting.

⇒ Do not touch or block the actuator stem.

ⓘ NOTICE

The process is disturbed by the movement of the actuator stem.

⇒ Do not perform zero calibration or initialization while the process is running. First isolate the plant by closing the shut-off valves.

During transit time measurement, the actuator stem moves from its current position to the 0 % end position. Starting from the 0 % end position, the actuator stem moves to the 100 % end position and back again to the 0 % end position. The transit time is measured during the up and down strokes and the average transit time calculated.

After the measurement is completed, the actuator returns to the operating mode last used.

i Note

The 0 % and 100 % end positions depend on the direction of action used (see Chapter 16).

Operation

Code	Description	Adjustment range
d61	Start transit time measurement	RUN
d62	Measured transit time in s	Read only
d63	Measured travel in mm	Read only
d64	Speed level	Read only

The transit time measurement can be canceled at all times by selecting **ESC**.

8.4.7 Displaying the actual value and changing the set point (PID and POSF applications)

Displaying the actual value

The current controlled variable is displayed in the operating level in Code 1.



The current position is displayed in the operating level in Code 0.

Reading and adjusting the set point

Version with rotary pushbutton

- When the applications PID controller (Code 6 = 'PID') and Temperature closed-loop control upon input signal failure (POSF) (Code 6 = 'POSF') are used, the adjusted set point (c81) is displayed in the operating level (Code 1) while the rotary pushbutton is pressed. The set point is adjusted in the CO configuration level (Code 10) in Code c81.

Version with three-key operation

- When the applications PID controller (Code 6 = 'PID') and Temperature closed-loop control upon input signal failure (POSF) (Code 6 = 'POSF') are used, the adjusted set point (c81) is displayed in the operating level (Code 1) while the selector key  is pressed. The set point can be adjusted by pressing the selector key together with one of the cursor keys ( or ). Alternatively, the set point can be adjusted while the key number operation (c94 = 'YES') is activated without entering a key number beforehand.

9 Malfunctions

9.1 Troubleshooting

⇒ See Table 11.

i Note

Contact SAMSON's After-sales Service for malfunctions not listed in the table.

Table 11: Troubleshooting

Malfunction	Possible reasons	Recommended action
Actuator stem does not move.	Actuator is blocked.	⇒ Check attachment. ⇒ Remove the blockage.
	No or incorrect supply voltage connected.	⇒ Check the supply voltage and connections.
Actuator stem does not move through its full range.	No or incorrect supply voltage connected.	⇒ Check the supply voltage and connections.
The actuator does not control the valve position.	The actuator was not initialized or not correctly initialized during start-up.	⇒ Initialize the actuator. ⇒ Take corrective action according to the error code (see Chapter 9.3).
	The mounting position has been changed.	

9.2 Emergency action

The valve, on which the electric actuator with fail-safe action is mounted, is moved to its fail-safe position upon supply voltage failure (see Chapter 3).

Plant operators are responsible for emergency action to be taken in the plant.

💡 Tip

Emergency action in the event of valve failure is described in the associated valve documentation.

9.3 Error messages

Active errors are added at the end of the top operating level. An error is indicated by the display blinking and alternating between the start screen and the indicated error with the  error icon. If several errors have occurred, only the error with the highest priority is shown on the start screen. In the operating level, the active errors appear on the display after Code 20.

Malfunctions

Table 12: Error messages in order of their priority

Error		Message	Type of error	Priority
EF	ENDT	Final test failed	Fatal errors	1
E11	NTRV	EEPROM error: no basic setting	Fatal errors	2
E12	NCO	EEPROM error: no configuration	Fatal errors	3
E08	PLU	Plausibility error	Fatal errors	4
E06	MOT	Motor or potentiometer not turning	Fatal errors	5
E03	SWI	Both limit contacts active	Fatal errors	6
E04	SIN	Retracting of actuator stem canceled	Fatal errors	7
E05	SOUT	Extending of actuator stem canceled	Fatal errors	8
E02	BLOC	Blockage	Fatal errors	9
E01	FAIL	Input signal failure (application: positioner)	Fatal errors	10
		Input signal failure (application: temperature closed-loop control upon input signal failure)	Maintenance demanded	
E07	SENS	Sensor failure (application: PID controller)	Fatal errors	11
		Sensor failure (application: temperature closed-loop control upon input signal failure)	Maintenance demanded	
E09	BUS	Bus failure	Fatal errors	12
E14	NPOT	EEPROM error: no potentiometer calibration	Maintenance demanded	13
E00	RUNT	No initialization performed	Maintenance demanded	14
E13	NCAL	EEPROM error: no calibration	Maintenance demanded	15
E15	NRUN	EEPROM error: no transit time	Maintenance demanded	16

i Note

If the E06 error is generated, it is possible to move the actuator stem of an actuator with fail-safe action by placing a 4 mm wrench on the actuating shaft and turning it. In this case, the supply voltage must be connected. The positioning value of the positioner does not cause the stem to move when this error occurs.

Table 13: Memory pen error

Code	Error	Text
E51	Read error (memory pen)	ERD
E52	Write error (memory pen)	EWR
E53	Plausibility error	EPLA

Comment on plausibility error

Due to an invalid combination of interacting parameters in the configuration level, a plausibility error arises which is indicated by **PLAU** blinking on the display. A correction of the interacting parameters clears the error message.

Causes of plausibility error

- Invalid application selected (when Code c01 = **C**): 'Pt1000' (Code c01 = **C**) is set as the source (only available for PID controller application, Code 6 = **PID**). Afterwards, the application is changed to 'Positioner' (Code 6 = **POSI**) or 'Temperature closed-loop control upon input signal failure' (Code 6 = **POSF**), causing a plausibility error. Recommended action: Set Code 6 to **PID**.
- Invalid application selected (when Code c01 = **VIA**): 'Interface' is set as the source (Code c01 = **VIA**). Afterwards, the application is changed to 'Temperature closed-loop control upon input signal failure' (Code 6 = **POSF**), causing a plausibility error. Recommended action: Set Code 6 to **POSI** or **PID**.
- Invalid value for lower range value (Code c02): A value <1.0 mA or <0.5 V is set in Code c02 combined with an active detection of input signal failure (Code c31 = **YES**). Recommended action: Set Code c31 to **NO** or Code c02 to a value ≥ 1.0 mA or ≥ 0.5 V.
- Invalid value for lower range value during fast configuration (FCO): Lower range value (Code c02) and active detection of input signal failure (Code c31 = **YES**) are a valid combination. However, a plausibility error arises if an input signal from 0 to 20 mA or 0 to 10 V is selected through fast configuration (**FCO**). Recommended action: Set Code c02 to a value ≥ 1.0 mA or ≥ 0.5 V.
- Invalid set point (Code c81): The set point (Code c81) is not within the range defined by the lower (Code c86) and upper adjustment limits (Code c87). Recommended action: Set the set point (Code c81) or the adjustment limits (Code c86/c87) so that the set point is within the adjustment limits.
- Invalid limits of process variable range (Code c88/c89): The set point (Code c81) is within the range defined by the lower (Code c86) and upper (Code c87) adjustment limits. The lower limit of process variable range (Code c88) has a greater value than the lower adjustment limit (Code c86) or the upper limit of process variable range (Code c89) has a lower value than the upper adjustment limit (Code c87). Recommended action: Adjust the limits of the process variable range (Code c88/c89) so that they are identical to the adjustment limits (Code c86/c87) or that the adjustment limits (Code c86/c87) are within the limits of the process variable range (Code c88/c89). See Appendix A (configuration instructions).

Tip

SAMSON recommends performing a reset to default settings and reconfiguration (see Chapter 8) if plausibility problems due to changes in various parameters cannot be rectified.

Malfunctions

Table 14: *Troubleshooting*

Code	Error	Corrective action to be taken
Fatal errors		
EF	Final test failed	Contact our after-sales service.
E01	Input signal failure	Check signal source and wiring.
E02	Blockage	Unblock actuator stem and valve.
E03	Both limit contacts active	Contact our after-sales service.
E04	Retracting of actuator stem canceled	Contact our after-sales service.
E05	Extending of actuator stem canceled	Contact our after-sales service.
E06	Motor or potentiometer not turning	Contact our after-sales service.
E07	Sensor failure	Check signal source and wiring.
E08	Plausibility error	Correct configuration.
E09	Bus failure	Check Modbus master and connection.
E11	EEPROM error: no basic setting	Contact our after-sales service.
E12	EEPROM error: no configuration	Perform configuration again.
Maintenance demanded		
E01	Input signal failure	Check signal source and wiring.
E07	Sensor failure	Check signal source and wiring.
E00	No initialization performed	Perform an initialization.
E13	EEPROM error: no calibration	Contact our after-sales service.
E14	EEPROM error: no potentiometer calibration	Contact our after-sales service.
E15	EEPROM error: no transit time	Perform an initialization or transit time measurement.
Warnings (in the service level)		
d41	EEPROM error: no serial number	Contact our after-sales service.
d42	EEPROM error: no manufacturing parameters	Contact our after-sales service.
d44	EEPROM error: no status messages	Contact our after-sales service.
d45	EEPROM error: no statistics	Contact our after-sales service.

i Note

EEPROM errors are marked by E RD on the display when they are read errors and E WR when they are write errors.

10 Servicing

The work described in this chapter is to be performed only by personnel appropriately qualified to carry out such tasks.

i Note

The electric actuator was checked by SAMSON before it left the factory.

- *The product warranty becomes void if service or repair work not described in these instructions is performed without prior agreement by SAMSON's After-sales Service.*
 - *Only use original spare parts by SAMSON, which comply with the original specifications.*
-

The actuator requires no maintenance.

SAMSON recommends inspection and testing according to the following table:

Table 15: *Recommended inspection and testing*

Inspection and testing	Action to be taken in the event of a negative result
Check the markings, labels and nameplates on the device for their readability and completeness.	⇒ Immediately renew damaged, missing or incorrect nameplates or labels. ⇒ Clean any inscriptions that are covered with dirt and are illegible.
Check the electric wiring.	⇒ Tighten any loose terminal screws (see Chapter 5.5). ⇒ Renew damaged wires.

💡 Tip

The SAMSON NE53 newsletter keeps users up to date on any software or hardware revisions in accordance with NAMUR Recommendation NE 53. Subscribe to the NE53 newsletter at ► www.samsongroup.com > SERVICE > NE53 newsletter.

11 Decommissioning

The work described in this chapter is to be performed only by personnel appropriately qualified to carry out such tasks.

i Note

Actuator with fail-safe action move to the defined fail-safe position after the supply voltage is switched off.

⚠ DANGER

Risk of fatal injury due to electric shock.

- ⇒ Before disconnecting live wires at the device, disconnect the supply voltage and protect it against unintentional reconnection.
-

⚠ WARNING

Risk of personal injury due to residual process medium in the valve.

While working on the valve, residual medium can flow out of the valve and, depending on its properties, cause personal injury, e.g. (chemical) burns.

- ⇒ Wear protective clothing, safety gloves and eye protection.
-

⚠ WARNING

Risk of burn injuries due to hot or cold components and pipeline.

Valve components and the pipeline may become very hot or cold. Risk of burn injuries if touched.

- ⇒ Allow components and pipeline to cool down or warm up to ambient temperature.
- ⇒ Wear protective clothing and gloves.
-

To put the electric actuator out of operation for repair work or disassembly, proceed as follows:

- ⇒ Put the control valve out of operation (see associated valve documentation).
- ⇒ Disconnect the supply voltage and protect it against unintentional reconnection.
- ⇒ Make sure that a signal from the controller cannot act upon the actuator.
-

i Note

For versions with "Actuator stem extends" fail-safe action, the supply voltage must remain connected to prevent the actuator stem extending by itself.

12 Removal

The work described in this chapter is to be performed only by personnel appropriately qualified to carry out such tasks.

⚠ DANGER

Risk of fatal injury due to electric shock.

⇒ *Before disconnecting live wires at the device, disconnect the supply voltage and protect it against unintentional reconnection.*

⚠ WARNING

Risk of personal injury due to hot components.

⇒ *If necessary, allow the pipeline and valve components to cool down.*

⚠ WARNING

Risk of personal injury due to residual process medium in the valve.

While working on the valve, residual medium can flow out of the valve and, depending on its properties, cause personal injury, e.g. (chemical) burns.

⇒ *Wear protective clothing, safety gloves and eye protection.*

12.1 Construction with integrated yoke

Actuator without fail-safe action

1. Check that the actuator is de-energized.
2. Make sure that a signal from the controller cannot act upon the actuator. If necessary, disconnect the wires connecting the controller.
3. Disconnect and remove the wires of the connecting lines at the actuator.
4. Retract actuator stem as described in Chapter 8.2.1.
5. Undo the stem connector parts between the plug and actuator stems.
6. Loosen the nut at the yoke.
7. Lift the actuator off the valve.

Actuator with "Actuator stem extends" fail-safe action

1. Retract actuator stem as described in Chapter 8.2.1.
2. Undo the stem connector parts between the plug and actuator stems.
3. Loosen the nut at the yoke.
4. Make sure that a signal from the controller cannot act upon the actuator. If necessary, disconnect the wires connecting the controller. The actuator stem moves to the fail-safe position.
5. Disconnect the supply voltage and protect it against unintentional reconnection.
6. Disconnect the wires of the connecting lines at the actuator.
7. Remove the connecting lines.
8. Lift the actuator off the valve.

Actuator with "Actuator stem retracts" fail-safe action

1. Check that the actuator is de-energized.
2. Make sure that a signal from the controller cannot act upon the actuator. If necessary, disconnect the wires connecting the controller.
3. Disconnect the wires of the connecting lines at the actuator.
4. Remove the connecting lines.
5. Undo the stem connector parts between the plug and actuator stems.
6. Loosen the nut at the yoke.
7. Lift the actuator off the valve.

12.2 Construction with ring nut

Actuator without fail-safe action

1. Check that the actuator is de-energized.
2. Make sure that a signal from the controller cannot act upon the actuator. If necessary, disconnect the wires connecting the controller.
3. Disconnect the wires of the connecting lines at the actuator.
4. Remove the connecting lines.
5. Retract actuator stem as described in Chapter 8.
6. Undo the stem connector parts between the plug and actuator stems.
7. Undo the top ring nut or hex nut.
8. Lift the actuator off the valve.

Removal

Actuator with “Actuator stem extends” fail-safe action

1. Retract actuator stem as described in Chapter 8.
2. Undo the stem connector parts between the plug and actuator stems.
3. Undo the top ring nut or hex nut.
4. Make sure that a signal from the controller cannot act upon the actuator. If necessary, disconnect the wires connecting the controller.
5. Disconnect the supply voltage and protect it against unintentional reconnection.
The actuator stem moves to the fail-safe position.
6. Disconnect the wires of the connecting lines at the actuator.
7. Remove the connecting lines.
8. Lift the actuator off the valve.

Actuator with “Actuator stem retracts” fail-safe action

1. Check that the actuator is de-energized.
2. Make sure that a signal from the controller cannot act upon the actuator. If necessary, disconnect the wires connecting the controller.
3. Disconnect the wires of the connecting lines at the actuator.
4. Remove the connecting lines.
5. Undo the stem connector parts between the plug and actuator stems.
6. Undo the top ring nut or hex nut.
7. Lift the actuator off the valve.

13 Repairs

If the actuator does not function properly according to how it was originally sized or does not function at all, it is defective and must be repaired or exchanged.

NOTICE

Risk of actuator damage due to incorrect service or repair work.

- ⇒ *Do not perform any repair work on your own.*
- ⇒ *Contact SAMSON's After-sales Service for service and repair work.*

13.1 Returning the actuator to SAMSON

Defective actuators can be returned to SAMSON for repair. Proceed as follows to return devices:

1. Remove the electric actuator from the valve (see Chapter 12).
2. Proceed as described on our website at
▶ www.samsongroup.com > SERVICE > After-sales Service > Returning goods.

Note

Further information on returned devices and how they are handled can be found at:

- ▶ www.samsongroup.com > Service > After-sales Service

14 Disposal

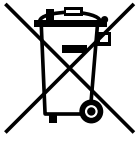

SAMSON is a producer registered in Europe, agency in charge

► www.samsongroup.com > About SAMSON > Environment, Social & Governance > Material Compliance > Waste electrical and electronic equipment (WEEE)
WEEE reg. no.: DE 62194439

Information on substances listed as substances of very high concern (SVHC) on the candidate list of the REACH regulation can be found in the document "Additional Information on Your Inquiry/Order", which is added to the order documents, if applicable. This document includes the SCIP number assigned to the devices concerned. This number can be entered into the database on the European Chemicals Agency (ECHA) website (► <https://www.echa.europa.eu/scip-database>) to find out more information on the SVHC contained in the device.

i Note

SAMSON can provide you with a recycling passport on request. Simply e-mail us at aftersaleservice@samsongroup.com giving details of your company address.

💡 Tip

On request, SAMSON can appoint a service provider to dismantle and recycle the product as part of a distributor take-back scheme.

- ⇒ Observe local, national and international refuse regulations.
- ⇒ Do not dispose of components, lubricants and hazardous substances together with your other household waste.

15 Certificates

The following certificates are included on the next pages:

- EU declarations of conformity
- Declaration of incorporation

The certificates shown were up to date at the time of publishing. The latest certificates can be found on our website:

▶ www.samsongroup.com > Products > Actuators > 3374



EU Konformitätserklärung / EU Declaration of Conformity / Déclaration UE de conformité

Die alleinige Verantwortung für die Ausstellung dieser Konformitätserklärung trägt der Hersteller/
This declaration of conformity is issued under the sole responsibility of the manufacturer/
La présente déclaration de conformité est établie sous la seule responsabilité du fabricant.

Für das folgenden Produkte / For the following product/ Nous certifions que les produit

Elektrischer Stellantrieb / Electric Actuator / Servomoteur électrique Typ/Type/Type 3374

wird die Konformität mit den einschlägigen Harmonisierungsrechtsvorschriften der Union bestätigt /
the conformity with the relevant Union harmonisation legislation is declared with/
sont conformes à la législation applicable harmonisée de l'Union:

EMC 2014/30/EU	EN 61000-6-2:2005, EN 61000-6-3:2007/A1:2011, EN 61326-1:2013
LVD 2014/35/EU	EN 60730-1:2011, EN 61010-1:2010/A1:2019
RoHS 2011/65/EU	EN IEC 63000:2018

Hersteller / Manufacturer / Fabricant:

SAMSON AKTIENGESELLSCHAFT
Weismüllerstraße 3
D-60314 Frankfurt am Main
Deutschland/Germany/Allemagne

Frankfurt / Francfort, 2022-10-05

Im Namen des Herstellers/ On behalf of the Manufacturer/ Au nom du fabricant.

Marcus Miertz
Senior Vice President Sales and Marketing

Gert Nahler
Director Automation Technology

EU DECLARATION OF CONFORMITY



Translation of the German original

Module D / N° CE-0062-PED-D-SAM 001-25-DEU-rev-A

For the following products, SAMSON hereby declares under its sole responsibility:

Devices	Series	Type	Version
Control valve for hot water and steam with fail-safe action in heating systems	3374-25/-27 Actuator (1800 N/3000 N force)		Type 3374-25 with Type 3241, 42-36 E (2423E), Type 3374-27 with Type 3241, 3214 (2814), Certificate no.: 01 202 969/B-24-0010, typetested according to DIN EN 14597:2015
Control valve for hot water and steam with fail-safe action in heating systems	3374-21/-26 Actuator (2000 N force)		With Type 3241, 42-36 E, 3214, 3321, 3531 EU-type examination (production type), Module B, Certificate no.: CE-0062-PED-B3.1-SAM 001-26-DEU, typetested according to DIN EN 14597:2015
Control valve for water and steam with fail-safe action in heating systems	5725-310/-313/-320/-323 Actuator 5725-810/-820 Actuator 5825-10/-13/-20/-23 Actuator (500 N force) (model number 2770)		With Type 3214 (2814), 2423 (2823), 3213 (2710), 3222 (2710), 2488 (2730), 2489 (2730) EU-type examination (production type), Module B, Certificate no.: 01 202 641/B-19-0017-01, typetested according to DIN EN 14597:2015, Annex DX
Control valve for water and steam with fail-safe action in heating systems	5827-A11/-A12/-A14/-A15 Actuator 5827-A21/-A22/-A24/-A25 Actuator		With Type 3214 (2814), 2423 (2823), 3213 (2710), 3222 (2710), 2488 (2730), 2489 (2730) EU-type examination (production type), Module B, Certificate no.: 01 202 641/B-19-0017-01, typetested according to DIN EN 14597:2015, Annex DX
Safety shut-off device for gas burners and gas equipment	240	3241G Valve	Equipment for gas and pressure devices Shut-off valve, automatic, valve class D Types 3241-1-Gas and 3241-7-Gas Material 1.0619 or 1.4408, soft seal with bellows, DN 15 to 150, PN 40 Type 3271 or 3277 Actuator with 3/2-way solenoid valve, EU-type examination (production type), Module B, Certificate no.: CE-0062-PED-B3.1-SAM 001-24-DEU

Conformity with the following requirement:

Directive of the European Parliament and of the Council on the harmonization of the laws of the Member States relating to the making available on the market of pressure equipment	2014/68/EU	of 15 May 2014
Conformity assessment procedure applied for liquids according to Article 4(1)	Module D	Certificate no.: N°CE-0062-PED-D-SAM 001-25-DEU-rev-A by Bureau Veritas 0062

The manufacturer's quality management system is monitored by the following notified body:

Bureau Veritas Services SAS, 4 place des Saisons, 92400 Courbevoie, France

Applied harmonized standards and technical standards: EN 16668, ASME B16.34, EN 60534-4, DIN EN 161:2013-04 (3241G), DIN EN 16678:2016-02 (3241G)

Manufacturer: SAMSON AKTIENGESELLSCHAFT, Weismüllerstraße 3, 60314 Frankfurt am Main, Germany

Frankfurt am Main, 25 February 2026



Dr. Andreas Widl
Chairman of the Executive Board (CEO)

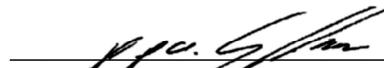

ppa. Sebastian Kräuse
Vice President Product Development

EU DECLARATION OF CONFORMITY TRANSLATION



Declaration of Conformity of Final Machinery

in accordance with Annex II, section 1.A. of the Directive 2006/42/EC

For the following product:

Type 3214/XXXX Electric Control Valve consisting of Type 3214 Valve and Type 3374, Type 3274 or Type 3375 Actuator

We hereby declare that the machinery mentioned above complies with all applicable requirements stipulated in Machinery Directive 2006/42/EC.

For product descriptions refer to:

- Types 3214/3374, 3214/3274, 3214/3375 Electric Control Valves:
Mounting and Operating Instructions EB 5868-1

Referenced technical standards and/or specifications:

- VCI, VDMA, VGB: "Leitfaden Maschinenrichtlinie (2006/42/EG) – Bedeutung für Armaturen, Mai 2018" [German only]
- VCI, VDMA, VGB: "Zusatzdokument zum Leitfaden Maschinenrichtlinie (2006/42/EG) – Bedeutung für Armaturen vom Mai 2018" [German only], based on
DIN EN ISO 12100:2011-03

Comment:

Information on residual risks of the machinery can be found in the mounting and operating instructions of the valve and actuator as well as in the referenced documents listed in the mounting and operating instructions.

Persons authorized to compile the technical file:

SAMSON AG, Weismüllerstraße 3, 60314 Frankfurt am Main, Germany
Frankfurt am Main, 14 January 2025

A handwritten signature in blue ink that reads "Steffen Runkwitz".

Steffen Runkwitz
Vice President
Global Sourcing

A handwritten signature in blue ink that reads "i. V. P. Scheermesser".

Peter Scheermesser
Director
Product Maintenance & Engineered Products

EU DECLARATION OF CONFORMITY

TRANSLATION



Declaration of Conformity of Final Machinery

in accordance with Annex II, section 1.A. of the Directive 2006/42/EC

For the following product:

Type 3214/XXXX-X Electric Control Valve consisting of Type 3214 Valve and TROVIS 5724-X, TROVIS 5725-X, Type 5824, Type 5825, Type 5827, Type 3274 or Type 3374 Actuator

We hereby declare that the machinery mentioned above complies with all applicable requirements stipulated in Machinery Directive 2006/42/EC.

For product descriptions refer to:

- Type 3214/... Electric and Pneumatic Control Valves:
Mounting and Operating Instructions EB 5868/5869

Referenced technical standards and/or specifications:

- VCI, VDMA, VGB: "Leitfaden Maschinenrichtlinie (2006/42/EG) – Bedeutung für Armaturen, Mai 2018" [German only]
- VCI, VDMA, VGB: "Zusatzdokument zum Leitfaden Maschinenrichtlinie (2006/42/EG) – Bedeutung für Armaturen vom Mai 2018" [German only], based on DIN EN ISO 12100:2011-03

Comment:

Information on residual risks of the machinery can be found in the mounting and operating instructions of the valve and actuator as well as in the referenced documents listed in the mounting and operating instructions.

Persons authorized to compile the technical file:

SAMSON AG, Weismüllerstraße 3, 60314 Frankfurt am Main, Germany
Frankfurt am Main, 10 October 2023

A handwritten signature in blue ink, appearing to read "ppc. Norbert Tollas".

Norbert Tollas
Senior Vice President
Global Operations

A handwritten signature in blue ink, appearing to read "i.v.P. Peter Scheermesser".

Peter Scheermesser
Director
Product Maintenance & Engineered Products

DECLARATION OF INCORPORATION

TRANSLATION



Declaration of Incorporation in Compliance with Machinery Directive 2006/42/EC

For the following product:

Type 3374 Actuator

We certify that the Type 3374 Electric Actuator is partly completed machinery as defined in the Machinery Directive 2006/42/EC and that the safety requirements stipulated in Annex I, 1.1.2, 1.1.3, 1.1.5, 1.2.1, 1.2.2, 1.2.3, 1.2.5, 1.2.6, 1.3.1, 1.3.2, 1.3.3, 1.3.4, 1.3.7, 1.3.9, 1.4.1, 1.5.3, 1.5.4 and 1.5.8 are observed. The relevant technical documentation described in Annex VII, part B has been compiled.

Products we supply must not be put into service until the final machinery into which it is to be incorporated has been declared in conformity with the provisions of the Machinery Directive 2006/42/EC.

Operators are obliged to install the products observing the accepted industry codes and practices (good engineering practice) as well as the mounting and operating instructions. Operators must take appropriate precautions to prevent hazards that could be caused by the process medium and operating pressure in the valve as well as by the signal pressure and moving parts.

The permissible limits of application and mounting instructions for the products are specified in the associated mounting and operating instructions; the documents are available in electronic form on the Internet at www.samsongroup.com.

For product descriptions refer to:

- Type 3374 Electric Actuator: Mounting and Operating Instructions EB 8331-3/EB 8331-4

Referenced technical standards and/or specifications:

- VCI, VDMA, VGB: "Leitfaden Maschinenrichtlinie (2006/42/EG) – Bedeutung für Armaturen, Mai 2018" [German only]
- VCI, VDMA, VGB: "Zusatzdokument zum Leitfaden Maschinenrichtlinie (2006/42/EG) – Bedeutung für Armaturen vom Mai 2018" [German only], based on DIN EN ISO 12100:2011-03

Comments:

- See mounting and operating instructions for residual hazards.
- Also observe the referenced documents listed in the mounting and operating instructions.

Persons authorized to compile the technical file:

SAMSON AG, Weismüllerstraße 3, 60314 Frankfurt am Main, Germany
Frankfurt am Main, 27 April 2022

Stephan Giesen
Director
Product Management

Sebastian Krause
Director
Development Valves and Actuators

16 Appendix A (configuration instructions)

16.1 Key number

To change parameters in the configuration level, a key number can be activated in the actuator using Code c94. When the key number function is activated, the key number must be entered before the parameter setting can be changed. If a code is selected without entering a key number beforehand when the key number function is activated, **LOCK** is displayed and the parameter settings cannot be changed.

Code	Description	Default	Adjustment range
c94	Key number active	NO	NO (deactivated) YES (activated)

1. Turn  (when the start screen appears) to select Code 9.

2. Press  to confirm.

Display: Input field for key number



3. Press  to activate the input field.



4. Turn  to enter the service key number.

The service key number can be found at the end of these mounting and operating instructions.



5. Press  to confirm.

The  icon indicates that the configuration level is enabled to change the parameter.

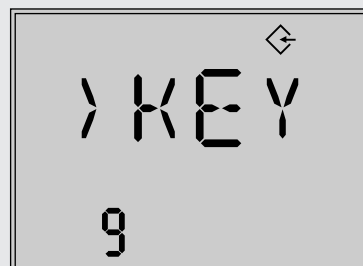

After entering the key number, the corresponding levels are enabled for five minutes (indicated by  icon). The levels are automatically locked again after five minutes.

The levels can also be locked again: select Code 9. **OFF** is displayed. After confirming it by pressing , the icon disappears.

Customized key number

In addition to the fixed service key number, a customized key number can be used. It is entered in the same way as the service key number in Code 9 and is set by default to **0000**. You can change the cus-

tomized key number in Code c92. The service key number becomes effective if the customized key number is deactivated in Code c91.

Code	Description	Default	Adjustment range
c91	Customized key number active	YES	NO (deactivated) YES (activated)
c92	Customized key number	0000	0000 to 1999

Tip

An additional write protection function can be achieved by deactivating the communication in Code A51 or Code A61 (see Chapter 7).

16.2 Input signal

The input signal determines the actuator stem position. Either a current or voltage signal can be applied to the input. Alternatively, the set point can be determined over the interface. It is adjusted over the configuration (Code c01). The default lower and upper range values of the input signal are between 4 and 20 mA. The input signal range can be adapted as required, e.g. to achieve a plant operation characteristic by connecting two or more actuators in parallel (split-range operation).

Example:

Two valves regulate the process medium in one common pipeline to achieve a large rangeability. For example, one valve opens with a 0 to 5 V input signal, while the second valve also opens when the input signal increases further (5 to 10 V) and the first valve remains open. The two valves close in the reverse order.

Code	Description	Default	Adjustment range
c01	Source (depending on the selected application)	mA	mA (current signal) V (voltage signal) C (Pt1000) VIA (via interface)
c02	Lower range value	4.0 mA	0.0 to 15.0 mA
c03	Upper range value	20.0 mA	5.0 to 20.0 mA

Note

The possible adjustment ranges are described in Chapter 16.14.2.

Detect input signal failure

The actuator detects a configured failure of the input signal and the error reading **E01** starts to blink on the display as soon as the input signal falls below the lower range value by 0.3 V or 0.6 mA. If the input signal failure function is active (c31 = **YES**), the reaction of the actuator upon failure of the input signal is determined by Code c32:

- **Internal positioning value (c32 = INT):** The actuator stem moves to the position specified in Code c33 upon failure of the input signal.
- **Last position (c32 = LAST):** The actuator stem remains in the last position that the valve moved to before failure of the input signal.

The error message is reset and the actuator returns to closed-loop operation if the input signal moves within 0.2 V or 0.4 mA of the lower range value.

Appendix A (configuration instructions)

Code	Description	Default	Adjustment range
c31	Detect input signal failure	NO	NO (function inactive) YES (function active)
c32	Positioning value upon input signal failure	INT	INT (internal positioning value) LAST (last position)
c33	Internal positioning value	0.0 %	0.0 to 100.0 %

i Note

The 0 to 10 V or 0 to 20 mA setting for the input signal is not possible in combination with this function. The lower value must be at least 0.5 V or 1 mA to ensure a signal failure can be detected.

16.3 Direction of action

- **Increasing/increasing (c42 = >>):**
The actuator stem retracts as the input signal increases.
- **Increasing/decreasing (c42 = <>):**
The actuator stem extends as the input signal increases.

Code	Description	Default	Adjustment range
c42	Direction of action	>>	>> (increasing/increasing) <> (increasing/decreasing)

16.4 End position guiding

Direction of action: increasing/increasing

- **Value above limit (end position guiding) (c35):**
The actuator stem moves the valve to the **top end position** if the input signal reaches the 'Value above limit (end position guiding)'. Setting c35 = 100.0 % causes this function (end position guiding: valve open) with a retracting actuator stem to be deactivated.
- **Value below limit (end position guiding) (c36):**
The actuator stem moves the valve to the **bottom end position** if the input signal reaches the 'Value above limit (end position guiding)'. Setting c36 = 0.0 % causes this function (end position guiding: valve closed) with an extending actuator stem to be deactivated.

Direction of action: increasing/decreasing

- **Value above limit (end position guiding) (c35):**
The actuator stem moves the valve to the **bottom end position** if the input signal reaches the 'Value above limit (end position guiding)'. Setting c35 = 100.0 % causes this function (end position guiding: valve open) with a retracting actuator stem to be deactivated.
- **Value below limit (end position guiding) (c36):**
The actuator stem moves the valve to the **top end position** if the input signal reaches the 'Value below limit (end position guiding)'. Setting c36 = 0.0 % causes this function (end position guiding: valve closed) with an extending actuator stem to be deactivated.

Code	Description	Default	Adjustment range
c35	Value above limit (end position guiding)	97.0 %	50.0 to 100.0 %
c36	Value above limit (end position guiding)	1.0 %	0.0 to 49.9 %

The actuator stem moves to the end positions earlier if the end position guiding function is active.

16.5 Position feedback signal

The valve position feedback indicates the valve travel. It uses an analog signal issued at the terminal **U OUT** or **I OUT**. The span of the position feedback signal is adjusted over the lower and upper range valve parameters.

i Note

- At least 2.5 V or 5 mA (depending on the input signal used) must separate the upper and lower range values.
- When *c37* = YES, the position feedback signal is 12 V or 24 mA in the event of a fault.
- During initialization, transit time measurement or zero calibration, the position feedback signal is 0 V or 0 mA.

Code	Description	Default	Adjustment range
c05	Unit	mA	mA (current signal) V (voltage signal)
c06	Lower range value	4.0 mA	0.0 to 7.5 V or 0.0 to 15.0 mA
c07	Upper range value	20.0 mA	2.5 to 10.0 V or 5.0 to 20.0 mA
c37	Superimposing an error message	NO	YES (error reading active) NO (error reading inactive)

16.6 Binary input

The function of the binary input can be configured as required. Code *c12* is used to determine the switching state for the active function.

c12 = NINV: the binary input is active when the input terminals **IN 4 +/IN 4 -** are connected with each other.

c12 = INV: The binary input is active when the connection between the input terminals **IN 4 +/IN 4 -** is interrupted.

⇒ Do not connect an external supply voltage to the input terminals.

- **Inactive (c11 = NONE):**
No function is assigned to the binary input.
- **Priority operation (c11 = PRIO):**
The priority operation is triggered and the actuator stem moves to the position entered in Code *c34* as soon as the binary input changes to the active switching state. The valve leaves the priority operation and follows the input signal after the binary input changes to the inactive switching state.
- **Next entry in information level (c11 = NEXT):**
If the **NEXT** function is selected in Code *c11*, the first code of the information level (*i01*) is displayed as soon as binary input switching state is changed. After every new change to the active state, the next code of the information level appears (*i02*, *i03* etc.). The display returns to the start screen after all the codes of the information level have been displayed due to the binary input switching or when the binary input's switching state remains unchanged for five minutes.
- **Backlight (c11 = LAMP):**
When the binary input's switching state is active, the display backlight is switched on permanently.
- **Exit manual level for travel adjustment (c11 = MEND):**
When the binary input's switching state is active, the actuator exits the manual mode. The actuator stem moves to the valve position determined by the automatic mode.

Code	Description	Default	Adjustment range
c11	Function	NONE	NONE (inactive) PRIO (priority position) NEXT (next entry in information level) LAMP (backlight activated) MEND (exit manual level for travel adjustment)
c12	Switching state for active function	NINV	NINV (non-inverted) INV (inverted)
When c11 = PRIO			
c34	Travel for priority position	0.0 %	0.0 to 100.0 %

16.7 Binary output

The binary output is a floating contact. The function and switching state of the binary input can be configured as required.

- **Inactive (c15 = NONE):**
No function is assigned to the binary output.
- **Error indication (c15 = FAIL):**
When an error (❗ icon) is registered, the error message is issued at the binary output.
- **Limit contact (c15 = LIM):**
The binary output is used as an electronic limit contact (see Chapter 16.8). To configure this function, the required settings must be made in Codes c21 to c23. The use of the binary output as an electronic limit contact is independent from the optionally installed electronic limit contacts.
- **Priority position (c15 = PRIO):**
When the priority position function is active (c11 = PRIO), this is registered at the binary output after the actuator stem stops moving.
- **Adopt binary input's state (c15 = BIN):**
The binary output reproduces the logical state of the binary input.
- **Indicate manual mode (c15 = MAN):**
The binary output is active when the manual mode (MAN) is active (Code 2) or the manual level in TROVIS-VIEW is active.

Code	Description	Default	Adjustment range
c15	Function	NONE	NONE (inactive) FAIL (error indication) LIM (limit contact) PRIO (priority position) BIN (adopt binary input) MAN (indicate manual mode)
c16	Switching state for active function	NINV	NINV (non-inverted) INV (inverted)
When c15 = LIM			
c21	Electronic limit contact (binary output) Message in case of event	NONE	NONE (inactive) HIGH (value above limit) LOW (value below limit)
c22	Switching point of limit contact (binary output)	10.0 %	0.0 to 100.0 %
c23	Hysteresis of electronic limit contact (binary output)	1.0 %	0.0 to 10.0 %

16.8 Electronic limit contacts

The electronic limit contact can be triggered by the actuator stem position exceeding or falling below an adjustable switching point.

- **Triggered when the position exceeds the switching point:**
The limit contact is activated when the actuator stem position moves beyond the switching point. The limit contact is deactivated when the actuator stem moves below the switching point plus hysteresis.
- **Triggered when the position moves below the switching point:**
The limit contact is activated when the actuator stem position moves below the switching point. The limit contact is deactivated when the actuator stem position moves beyond the switching point plus 'Hysteresis'.

i Note

An activated limit contact remains permanently active if the switching point is smaller or larger than the hysteresis. This limit contact can only be deactivated by a restart (see Chapter 8) or by resetting to NONE (c24, c27).

Code	Description	Default	Adjustment range
c24	Limit contact 1: Message in case of event	NONE	NONE (inactive) HIGH (value above limit) LOW (value below limit)
c25	Switching point of limit contact 1	10.0 %	0.0 to 100.0 %
c26	Hysteresis of limit contact 1	1.0 %	0.0 to 10.0 %
c27	Limit contact 2: Message in case of event	NONE	NONE (inactive) HIGH (value above limit) LOW (value below limit)
c28	Switching point of limit contact 2	90.0 %	0.0 to 100.0 %
c29	Hysteresis of limit contact 2	1.0 %	0.0 to 10.0 %

16.9 Restart

After the supply voltage returns upon a supply voltage failure, the actuator starts according to the restart conditions.

- **Normal (c43 = NORM):**
The actuator remains in automatic mode and immediately follows the input signal.
- **Zero calibration (c43 = ZERO):**
The actuator performs a zero calibration.
- **Fixed positioning value (c43 = FIX):** The actuator switches to the manual mode and moves the actuator stem to the Fixed positioning value for restart.
- **Stop in manual level (c43 = STOP):**
The actuator switches to the manual mode and sets the last positioning value to be the same as the manual positioning value.

Code	Description	Default	Adjustment range
c43	Restart	NORM	NORM (normal) ZERO (zero calibration) FIX (fixed positioning value) STOP (stop in manual level)
When c43 = FIX			
c44	Fixed positioning value for restart	0.0 %	0.0 to 100.0 %

16.10 Blockage

Blockage detection

The actuator detects a valve blockage by comparing the travel after the torque switch has been triggered with the travel measured on initialization. If the comparison shows that the limit switch was triggered too early, this indicates that there is a valve blockage. A blockage is indicated on the display by the  icon.

Blockage removal

When the blockage removal function is active, the actuator stem extends and retracts 1 mm three times at the most in sequence.

Blocking protection

The blocking protection prevents the valve from seizing up. If the actuator stem is in the CLOSED position (0 %), it is extended slightly and then moved back to the closed position 24 hours after it last moved.

Code	Description	Default	Adjustment range
c51	Blockage detection	NO	NO (function inactive) YES (function active)
c52	Blockage removal	NO	NO (function inactive) YES (function active)
c53	Blocking protection	NO	NO (function inactive) YES (function active)

16.11 Travel

Limited travel range (c63)

The 'Limited travel range' parameter determines in % how far the actuator stem can move at the maximum. The rated travel (c61) acts as the reference. When c63 = 100.0 %, the travel range is not limited.

Code	Description	Default	Adjustment range
c61	Rated travel	mm	Read only
c63	Limited travel range	100.0 %	10.0 to 100.0 %

i Note

The output signal range is always covered by the adjusted travel range.

Speed (c64)

The actuator stem moves to the position determined by the input signal at the selected stroking speed. There are two different speed levels (**NORM** and **FAST**). The transit time (c66) is calculated from the travel and the stroking speed (c65). The transit time is the time that the actuator stem needs to move through the adjusted travel.

The following applies:

$$\text{Transit time in s} = \frac{\text{Travel in mm}}{\text{Stroking speed in mm/s}}$$

Code	Description	Default	Adjustment range
c62	Gear version		Read only
c64	Speed	NORM	NORM (normal) FAST
c65	Stroking speed	mm/s	Read only
c66	Transit time	s	Read only

Dead band (switching range)

The dead band suppresses slight movements of the stem. The dead band represents the sum of the positive and negative hysteresis. After the actuator has been stationary, the input signal must change by at least half of the dead band to cause the actuator stem to move again.

Code	Description	Default	Adjustment range
c67	Dead band (switching range)	2.0 %	0.5 to 5.0 %

16.12 Characteristic

The characteristic expresses the relation between the input signal and the actuator stem position (direction of action increasing/increasing >>).

– **Linear (c71 = LIN):**

The travel is proportional to the input signal.

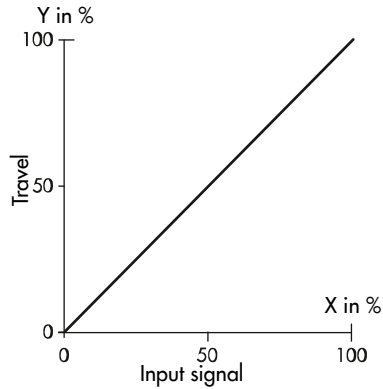

– **Equal percentage (c71 = EQUA):**

The travel is exponential to the input signal.

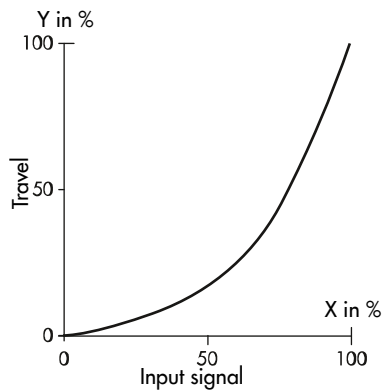

– **Reverse equal percentage (c71 = INV):**

The travel is reverse exponential to the input signal.

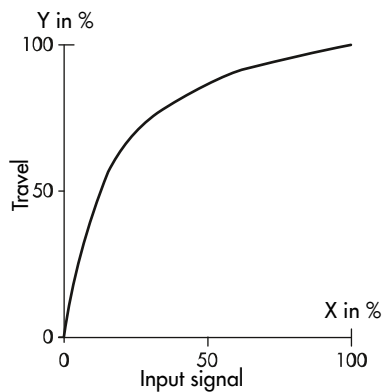

– **User-defined (c71 = USER, c72 = USE):**

A new characteristic based on the last characteristic used can be defined over eleven points.

Code	Description	Default	Adjustment range
c71	Characteristic type	LIN	LIN (linear) EQUA (equal percentage) INV (reverse equal percentage) USER (user-defined)
When c71 = USER:			
c72	User-defined characteristic		USE
H0, Y0	Input value X0, output value Y0	0.0 %	0.0 to 100.0 %
H1, Y1	Input value X1, output value Y1	10.0 %	0.0 to 100.0 %
H2, Y2	Input value X2, output value Y2	20.0 %	0.0 to 100.0 %
H3, Y3	Input value X3, output value Y3	30.0 %	0.0 to 100.0 %
H4, Y4	Input value X4, output value Y4	40.0 %	0.0 to 100.0 %
H5, Y5	Input value X5, output value Y5	50.0 %	0.0 to 100.0 %
H6, Y6	Input value X6, output value Y6	60.0 %	0.0 to 100.0 %
H7, Y7	Input value X7, output value Y7	70.0 %	0.0 to 100.0 %
H8, Y8	Input value X8, output value Y8	80.0 %	0.0 to 100.0 %
H9, Y9	Input value X9, output value Y9	90.0 %	0.0 to 100.0 %
H10, Y10	Input value X10, output value Y10	100.0 %	0.0 to 100.0 %

Inversing the characteristic

The points must be entered accordingly if the characteristic is to express the opposite relation between the input signal and the actuator stem position.

Table 16: Behavior with inverted characteristic

Non-inverted characteristic		Inverted characteristic	
Input value X in %	Output value X in %	Input value X in %	Output value X in %
0	0	0	100.0
10.0	10.0	10.0	90.0
20.0	20.0	20.0	80.0
30.0	30.0	30.0	70.0
40.0	40.0	40.0	60.0
50.0	50.0	50.0	50.0
60.0	60.0	60.0	40.0
70.0	70.0	70.0	30.0
80.0	80.0	80.0	20.0
90.0	90.0	90.0	10.0
100.0	100.0	100.0	0

Table 17: Actuator behavior with a non-inverted (linear) characteristic

Direction of action (c42)	Input signal in %	Output signal in %	Actuator stem position
Increasing/increasing >>	0	0	Extended
	100	100	Retracted
Increasing/decreasing <>	0	0	Retracted
	100	100	Extended

Table 18: Actuator behavior with an inverted (linear) characteristic

Direction of action (c42)	Input signal in %	Output signal in %	Actuator stem position
Increasing/increasing >>	0	100	Retracted
	100	0	Extended
Increasing/decreasing <>	0	100	Extended
	100	0	Retracted

16.13 Applications

⇒ Configuration settings (see Chapter 16.14.2).

16.13.1 Positioner

⇒ Code 6: Select 'POSI'.

The actuator travel follows directly the input signal.

The input signal is connected to one of the following inputs:

- IN1 (mA)
- IN2 (V)

Alternatively, the input signal can also be determined over the RS-485 communication interface (Modbus RTU).

Code	Parameters	Default	Adjustment range
Input signal			
c01	Source	mA	mA (current signal) V (voltage signal) VIA (via interface)
c02	Lower range value	4 mA	0.0 to 15.0 mA
		2.0 V	0.0 to 7.5 V
c03	Upper range value	20.0 mA	9.0 to 20.0 mA
		10.0 V	4.5 to 10.0 V

16.13.2 PID controller

⇒ Code 6: Select 'PID'.

Input signal

The input signal for the controlled variable is connected to one of the following inputs:

- IN1 (mA)
- IN2 (V)
- IN3 (Pt1000)

Alternatively, the input signal can also be determined over the RS-485 communication interface (Modbus RTU).

The type of input signal (source) for the controlled variable (mA, V, Pt1000, via interface) is adjusted in Code c01.

The input signal range for mA and V signals is determined by entering the lower range value (Code c02) and upper range value (Code c03).

When the **PID** application is used for temperature control with a Pt1000 sensor, the temperature sensor is connected at the IN3 input (see Chapter 5). Pt1000 sensors can also be connected to the IN1 and IN2 inputs. Their measured values can be read out over the RS-485 interface as Modbus data points (see Chapter 16.16).

Measuring range

The measuring range of the controlled variable is determined by entering the lower limit of range (Code c88) and upper limit of range (Code c89). mA and V input signals: the measuring range is set from -100 to +300 by default. The range limits can be adapted to the measuring range of the transmitter.

Pt 1000 input signal: the measuring range has a fixed range from -50 to +150 °C. The adjustment limits of process variable depend on the input signal (Code c01) and the adjusted unit (Code c85). See Table 19.

Table 19: Adjustment limits of the process variable depending on the associated parameters

Input signal c01	Parameters	Ranges	Unit c85			
			Without	%	°C	bar
mA/V/Interface	c88	Lower range value	-1000...+999	-	-100...+299	0...99
	c89	Upper range value	-999...+1000	-	-99...+300	1...100
Pt1000	c88	Lower range value	-	-	-50	-
	c89	Upper range value	-	-	+150	-

Set point

The set point is adjusted in Code c81. It can be displayed in the operating level in Code 1 (see Chapter 8).

Version with rotary pushbutton: the set point is displayed as long as the rotary pushbutton is pressed.

Version with three-key operation: the set point is displayed as long as the  selection key is pressed. The set point in this version can be adjusted by pressing the selector key together with one of the cursor keys.

The adjustment range for the set point is determined in Code c86 (lower adjustment limit) and Code c87 (upper adjustment limit) and is within the adjusted process variable range (see Fig. 55).

The adjustment limits of set point range depend on the adjusted input signal (Code c01) and the adjusted unit (Code c85). See Table 20. The following physical units can be set in Code c85:

- None
- %
- °C
- bar

Table 20: Adjustment limits of the set point depending on the associated parameters

Input signal c01	Parameters	Ranges	Unit c85			
			Without	%	°C	bar
mA/V/Interface	c86	Lower range value	-1000...+999	0...99	-100...+299	0...99
	c87	Upper range value	-999...+1000	1...100	-99...+300	1...100
Pt1000	c86	Lower range value	-	-	-50...+149	-
	c87	Upper range value	-	-	-49...+150	-

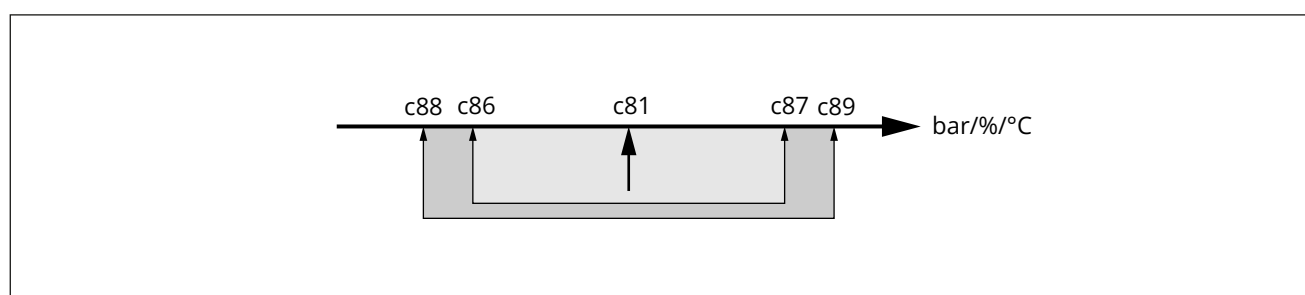

Fig. 55: Permissible set point adjustment limits and limits of process variable range (only for PID and POSF applications)

c81 Set point

c86 Lower adjustment limit of set point

c87 Upper adjustment limit of set point

c88 Lower limit of process variable range

c89 Upper limit of process variable range

Control parameters

The following parameters can be set to adapt the control response:

- Proportional-action coefficient K_p (Code c82)
- Reset time T_n (Code c83)
- Derivative-action time T_v (Code c84)
- Operating point Y_0 (Code c80)

The error (%) and the setting of the proportional-action coefficient K_p are based on a measuring span of 100. For example, a set point deviation of 5 °C and a proportional-action coefficient of 2 results in a travel of 10 %. The input measuring range setting does not have any effect on the control response.

A reset time $T_n = 0$ deactivates the I component.

A derivative-action time $T_v = 0$ deactivates the D component.

Direction of action

The direction of action of the process controller's error (non-inverted/inverted) is set in Code c90. The positioner's direction of action (increasing/increasing or increasing/decreasing) is set in Code c42.

Code	Parameters	Default	Adjustment range
Input signal			
c01	Source	mA	mA (current signal) V (voltage signal) C (Pt1000) VIA (via interface)
c02	Lower range value	4.0 mA	0.0 to 15.0 mA
		2.0 V	0.0 to 7.5 V
c03	Upper range value	20.0 mA	9.0 to 20.0 mA
		10.0 V	4.5 to 10.0 V
PID controller			
c80	Operating point Y_0	0 %	0 to 100 %
c81	Set point	50.0 %	0.0 to 100.0 %
c82	Proportional-action coefficient K_p	1.0	0.1 to 50.0
c83	Reset time T_n	20 s	0 to 999 s
c84	Derivative-action time T_v	0 s	0 to 999 s
Scaling of the set point for PID controller			
c85	Unit	CEL	NONE (none) PER (%) CEL (°C) BAR (bar)
c86	Lower adjustment limit	0	See Table 20.
c87	Upper adjustment limit	100	
Process variable setting			
c88	Lower limit of range	0	See Table 19.
c89	Upper limit of range	100	
Set point deviation			
c90	Function	1	0: Inverted 1: Not inverted

16.13.3 Two-step mode

⇒ Code 6: Select '2STP'.

The binary input **IN2** is used for this function. When the binary input is in the active switching state, the actuator stem retracts (100 % of the adjusted travel range). When the binary input is in the inactive switching state, the actuator stem moves to the closed position (0 %).

Code	Parameters	Default	Adjustment range
Input signal			
c04	Logic	1	0: Inverted 1: Non-inverted

16.13.4 Three-step mode

⇒ Code 6: Select '3STP'.

The binary input **IN 2** is used for this function to retract the actuator stem and binary input **IN 3** to extend the actuator stem.

Code	Parameters	Default	Adjustment range
Input signal			
c04	Logic	1	0: Inverted 1: Non-inverted

16.13.5 Temperature closed-loop control upon input signal failure

⇒ Code 6: Select 'POSF'.

The function in normal operation is the same as that of the 'Positioner' application (see Chapter 16.13.1). The actuator travel follows the input signal. The setting of the input signal (Codes c01, c02, c03) is based on the set point of the positioner. The input signal for the positioner is connected to one of the following inputs:

- IN1 (mA)
- IN2 (V)

Alternatively, the input signal can also be determined over the RS-485 communication interface (Modbus RTU).

Set point for temperature closed-loop control upon input signal failure

Upon failure of the input signal or violation of the adjusted lower range value, the set point (Code c81) determined in the actuator by the integrated PID controller is used to position the stem. For this purpose, a Pt1000 sensor must be connected to the input **IN3**. The unit of the set point is fixed to °C and the measuring has a fixed range (-50 °C to +150 °C). The adjustment range for the set point is determined in Code c86 (lower adjustment limit) and Code c87 (upper adjustment limit). See Fig. 55.

i Note

When the application Temperature closed-loop control upon input signal failure (POSF) is used, temperature control is only possible with a Pt1000 sensor upon input signal failure.

Version with rotary pushbutton: the set point is displayed as long as the rotary pushbutton is pressed.

Version with three-key operation: the set point is displayed as long as the selection key is pressed. The set point in this version can be adjusted by pressing the selector key together with one of the cursor keys.

The following parameters can be set to adapt the control response:

- Proportional-action coefficient K_p (Code c82)
- Reset time T_n (Code c83)
- Derivative-action time T_v (Code c84)
- Operating point Y_0 (Code c80)

The error (%) and the setting of the proportional-action coefficient K_p are based on a measuring span of 100.

Direction of action

The direction of action of the process controller's error is set in Code c90.

The positioner's direction of action (increasing/increasing or increasing/decreasing) is set in Code c42.

Code	Parameters	Default	Adjustment range
Input signal			
c01	Source	mA	mA (current signal) V (voltage signal) VIA (via interface)
c02	Lower range value	1.1 mA	1.0 to 15.0 mA
		0.6 V	0.5 to 7.5 V
c03	Upper range value	20.0 mA	9.0 to 20.0 mA
		10.0 V	4.5 to 10.0 V
PID controller			
c80	Operating point Y_0	0 %	0 to 100 %
c81	Set point	50.0 %	0.0 to 100.0 %
c82	Proportional-action coefficient K_p	1.0	0.1 to 50.0
c83	Reset time T_n	20 s	0 to 999 s
c84	Derivative-action time T_v	0 s	0 to 999 s
Scaling of the set point for PID controller			
c86	Lower adjustment limit	-50	-50 to +149
c87	Upper adjustment limit	+150	-49 to +150
Set point deviation			
c90	Function	1	0: Inverted 1: Not inverted

16.14 Levels and parameters

16.14.1 Operating level

Standard level during operation

Code	Parameters	Display/select (select ESC to cancel)	Chapter
Start screen			
0/1	Depending on application	Read only	⇒ Start-up and configuration
Operating level			
1	Positioning value	Read only	⇒ Start-up and configuration
2	Operating mode	AUTO (automatic mode) MAN (manual mode)	
3 ¹⁾	Positioning value (manual mode)	0.0 to 100.0 %	
4	Reading direction	DISP , dSID	
5	Start initialization	> INI	
6	Application	POSI (positioner) PID (PID controller) 2STP (two-step mode) 3STP (three-step mode) POSF (temperature closed-loop control upon input signal failure)	
8	Fast configuration level	IN, OUT, dir	
9	Key number	> KEY	
10	Activate the configuration level ⇒ See Chapter 16.14.2.	> CO	
11	Activate the information level ⇒ See Chapter 16.14.3.	> INF	
20	Activate the service level ⇒ See Chapter 16.14.4.	> SER	
23	Activate the communication level ⇒ See Chapter 16.14.5.	> COM	
Fatal errors (can only be seen when error exists)			
EF	Final test failed	ENDT	⇒ Malfunctions
E00	Error: No initialization performed	RUNT	
E01	Error: Input signal failure	FAIL	
E02	Error: Blockage	BLOC	
E03	Error: Both limit contacts active	SWI	
E04	Error: Canceled while retracting stem	SIN	
E05	Error: Canceled while extending stem	SOUT	
E06	Error: Motor or potentiometer not turning	MOT	
E08	Plausibility error	PLAU	
E09	Bus failure	BUS	

Code	Parameters	Display/select (select ESC to cancel)	Chapter
EEPROM errors (can only be seen when error exists)			
E11	Error: No basic setting	NTRV	⇒ Malfunc- tions
E12	Error: No configuration	NCO	
E13	Error: No calibration	NCAL	
E14	Error: No potentiometer calibration	NPOT	
E15	Error: No transit time	NRUN	

¹⁾ Only in manual mode (MAN)

16.14.2 Configuration level

Code 10, display: >CO

Code	Parameters	Adjustment range ¹⁾	Default	Application					Cus- tomer-specific da ta
				POSI	PID	2STP	3STP	POSF	
Input signal									
c01	Source	mA (current signal)	mA	✓	✓	-	-	✓	
		V (voltage signal)		✓	✓	-	-	✓	
		C (Pt1000)		-	✓	-	-	-	
		VIA (via interface)		✓	✓	-	-	✓	
POSI and PID application									
c02	Lower range value	0.0 to 15.0 mA ³⁾	4.0 mA	✓	✓	-	-	-	
		2.0 to 7.5 V ³⁾	2.0 V						
POSF application									
c02	Lower range value	1.0 to 15.0 mA ³⁾	4.0 mA	-	-	-	-	✓ ²⁾	
		0.0 to 7.5 V ³⁾	2.0 V						
c03	Upper range value	9.0 to 20.0 mA ³⁾	20 mA	-	-	-	-	✓ ²⁾	
		4.5 to 10.0 V ³⁾	10.0 V						
c04	Logic	0: Inverted 1: Non-inverted	1	-	-	✓	✓	-	
Position feedback signal									
c05	Unit	mA (current signal)	mA	✓	✓	✓	✓	✓	
		V (voltage signal)							
c06	Lower range value	0.0 to 15.0 mA ³⁾	4.0 mA	✓	✓	✓	✓	✓	
		0.0 to 7.5 V ³⁾	2.0 V						
c07	Upper range value	5.0 to 20.0 mA ³⁾	20.0 mA	✓	✓	✓	✓	✓	
		2.5 to 10.0 V ³⁾	10.0 V						
Binary input									

Appendix A (configuration instructions)

Code	Parameters	Adjustment range ¹⁾	Default	Application					Customer-specific data
				POSI	PID	2STP	3STP	POSF	
c11	Function	NONE (inactive) PRIO (priority position) NEXT (next entry in information level) LAMP (backlight activated) MEND (exit manual level for travel adjustment)	NONE	✓	✓	✓	✓	✓	
c12	Logic	NINV (non-inverted) INV (inverted)	NINV	✓ ²⁾	✓ ²⁾	✓ ²⁾	✓ ²⁾	✓ ²⁾	
Binary output									
c15	Function	NONE (inactive) FAIL (indicate error during operation) LIM (electronic limit contact) PRIO (priority position reached) BIN (adopt binary input) MAN (indicate manual mode)	NONE	✓	✓	✓	✓	✓	
c16	Logic	NINV (non-inverted) INV (inverted)	NINV	✓ ²⁾	✓ ²⁾	✓ ²⁾	✓ ²⁾	✓ ²⁾	
Electronic limit contact (binary output)									
c21	Message in case of event	NONE (inactive) HIGH (value above limit) LOW (value below limit)	NONE	✓	✓	✓	✓	✓	
c22	Switching point	0.0 to 100.0 %	10.0 %	✓ ²⁾	✓ ²⁾	✓ ²⁾	✓ ²⁾	✓ ²⁾	
c23	Hysteresis	0.0 to 10.0 %	1.0 %	✓ ²⁾	✓ ²⁾	✓ ²⁾	✓ ²⁾	✓ ²⁾	
Electronic limit contact 1									
c24	Message in case of event	NONE (inactive) HIGH (value above limit) LOW (value below limit)	NONE	✓	✓	✓	✓	✓	
c25	Switching point	0.0 to 100.0 %	10.0 %	✓ ²⁾	✓ ²⁾	✓ ²⁾	✓ ²⁾	✓ ²⁾	
c26	Hysteresis	0.0 to 10.0 %	1.0 %	✓ ²⁾	✓ ²⁾	✓ ²⁾	✓ ²⁾	✓ ²⁾	
Electronic limit contact 2									
c27	Message in case of event	NONE (inactive) HIGH (value above limit) LOW (value below limit)	NONE	✓	✓	✓	✓	✓	
c28	Switching point	0.0 to 100.0 %	90.0 %	✓ ²⁾	✓ ²⁾	✓ ²⁾	✓ ²⁾	✓ ²⁾	
c29	Hysteresis	0.0 to 10.0 %	1.0 %	✓ ²⁾	✓ ²⁾	✓ ²⁾	✓ ²⁾	✓ ²⁾	
Input signal									
c31	Detect input signal failure	YES NO	NO	✓	✓	-	-	✓	
c32	Positioning value upon input signal failure	INT (internal positioning value) LAST (last position)	INT	✓ ²⁾	✓ ²⁾	-	-	✓ ²⁾	
c33	Internal positioning value	0.0 to 100.0 %	0.0 %	✓ ²⁾	✓ ²⁾	-	-	✓ ²⁾	
c34	Travel for priority position	0.0 to 100.0 %	0.0 %	✓	✓	✓	✓	✓	

Code	Parameters	Adjustment range ¹⁾	Default	Application					Cus- tomer-specific da ta
				POSI	PID	2STP	3STP	POSF	
c35	End position guiding (stem retracts)	50.0 to 100.0 %	97 %	✓	✓	-	-	✓	
c36	End position guiding (stem extends)	0.0 to 49.9 %	1.0 %	✓	✓	-	-	✓	
c37	Superimposing an error message	YES (error reading active) NO (error reading inactive)	NO	✓	✓	✓	✓	✓	
Operation									
c42	Direction of action	>> (increasing/increasing) << (increasing/decreasing)	>>	✓	✓	-	-	✓	
c43	Restart	NORM (normal) ZERO (zero calibration) FIX (fixed positioning value) STOP (stop in manual level)	NORM	✓	✓	✓	✓	✓	
c44	Fixed positioning value for restart	0.0 to 100.0 %		✓ ²⁾	✓ ²⁾	✓ ²⁾	✓ ²⁾	✓ ²⁾	
Blockage									
c51	Blockage detection	NO (function inactive) YES (function active)	NO	✓	✓	✓	✓	✓	
c52	Blockage removal	NO (function inactive) YES (function active)	NO	✓ ²⁾	✓ ²⁾	✓ ²⁾	✓ ²⁾	✓ ²⁾	
c53	Blocking protection of valve	NO (function inactive) YES (function active)	NO	✓	✓	✓	✓	✓	
Travel									
c61	Rated travel	→ Read only		✓	✓	✓	✓	✓	
c63	Limited travel range	10.0 to 100.0 %	100.0 %	✓	✓	✓	✓	✓	
c64	Speed	NORM (normal) FAST	NORM	✓	✓	✓	✓	✓	
c65	Stroking speed	→ Read only		✓	✓	✓	✓	✓	
c66	Transit time	→ Read only		✓	✓	✓	✓	✓	
c67	Dead band (switching range)	0.5 to 5.0 %	2.0 %	✓	✓	✓	✓	✓	
Characteristic									
c71	Characteristic type	LIN (linear) EQUA (equal percentage) INV (reverse equal percentage) USER (user-defined)	LIN	✓	✓	-	-	✓	
c72	User-defined characteristic	User-defined		✓ ²⁾	✓ ²⁾	-	-	✓ ²⁾	
PID controller									
c80	Operating point Y_0	0 to 100 %	0 %	-	✓	-	-	✓	
c81	Set point	1.0 to 50.0 %	50.0 %	-	✓	-	-	✓	
c82	Proportional-action coefficient K_p	0.1 to 50.0	1.0	-	✓	-	-	✓	
c83	Reset time T_n	0 to 999 s	20 s	-	✓	-	-	✓	

Appendix A (configuration instructions)

Code	Parameters	Adjustment range ¹⁾	Default	Application					Customer-specific data
				POSI	PID	2STP	3STP	POSF	
c84	Derivative-action time T _v	0 to 999 s	0 s	-	✓	-	-	✓	
Scaling of the set point for PID controller									
c85	Unit	NONE (none) PER (%) CEL (°C) BAR (bar)	CEL	-	✓	-	-	-	
c86	Lower adjustment limit	⇒ See Chapter 16.13.2 and Chapter 16.13.5.	0	-	✓	-	-	✓	
c87	Upper adjustment limit	⇒ See Chapter 16.13.2 and Chapter 16.13.5.	100	-	✓	-	-	✓	
Process variable setting									
c88	Lower limit of range	PID application ⇒ See Chapter 16.13.2.	0	-	✓	-	-	✓ ³⁾	
		POSF application: -50							
c89	Upper limit of range	PID application ⇒ See Chapter 16.13.2.	100	-	✓	-	-	✓ ³⁾	
		POSF application: +150							
Set point deviation									
c90	Function	0: Non-inverted 1: Inverted	0	-	✓	-	-	✓	
Actuator									
c91	Customized key number active	NO (function inactive) YES (function active)	NO	✓ ²⁾	✓ ²⁾	✓ ²⁾	✓ ²⁾	✓ ²⁾	
c92	Customized key number	0000 to 1999	0000	✓ ²⁾	✓ ²⁾	✓ ²⁾	✓ ²⁾	✓ ²⁾	
c93	Backlight always on	NO (function inactive) YES (function active)	NO	✓	✓	✓	✓	✓	
c94	Key number is active	NO (function inactive) YES (function active)	NO	✓	✓	✓	✓	✓	

¹⁾ Select ESC to cancel

²⁾ Editing only possible after activation of a configuration item

³⁾ Depending on c01 setting

16.14.3 Information level

Code 11, display: >INF

Code	Parameters (read only)	Reading/unit	Chapter
Input signal			
i01	Lower range value of input signal	V or mA	⇒ Start-up and configuration
i02	Upper range value of input signal	V or mA	
i03	Positioning value	%/state	
i04	Unit	V or mA	
Control			
i05	Process variable	%/°C/bar/without unit	⇒ Start-up and configuration
i06	Set point	%/°C/bar/without unit	
i07	Set point deviation	%	
i08	Active controller	State	
i09	Positioning value	%	
Travel			
i11	Actuator travel	%	⇒ Start-up and configuration
i12	Actuator travel	mm	
Position feedback signal			
i21	Lower range value of position feedback signal	V or mA ¹⁾	⇒ Start-up and configuration
i22	Upper range value of position feedback signal	V or mA ¹⁾	
i23	Position feedback signal	%	
	Position feedback signal	V or mA ¹⁾	
Binary signals			
i31	Binary input status	ON/OFF	⇒ Start-up and configuration
i32	Binary output status	ON/OFF	
Limit contact			
i41	Status of limit contact (stem retracted)	ON/OFF	⇒ Start-up and configuration
i42	Status of limit contact (stem extended)	ON/OFF	
Configuration			
i51	Direction of action	>>/<<	⇒ Start-up and configuration
i52	Limited travel range	%	
i53	Transit time	s	
i54	Application	POSI/PID/2STP/3STP/ POSF	
Diagnostics			
i61	Full travel cycles	From 10000 onwards, reading in K	-
i62	Temperature inside actuator	°C	
i63	Lowest temperature inside actuator	°C	
i64	Highest temperature inside actuator [°C]	°C	
i00	Exit information level		

¹⁾ The mA unit is represented in the display by the icon .

16.14.4 Service level

Code 20, display: >SER

Code	Parameters (read only)	Reading/unit	Chapter
Information - Actuator			
d01	Firmware version	Read only	⇒ Markings on the device
d02	Revision number	Read only	
Errors - Status			
d10	Error during operation	Read only	⇒ Malfunctions
d11	Priority position triggered	YES NO	
Errors - Fatal errors			
d20	No initialization performed	Read only	⇒ Malfunctions
d21	Input signal failure	YES NO	
d22	Blockage		
d23	Both limit contacts active		
d24	Canceled while retracting stem		
d25	Canceled while extending stem		
d26	Motor or potentiometer not turning		
d26	Sensor failure		
Errors - EEPROM errors			
d31	EEPROM error: Basic setting	Read only	⇒ Malfunctions
d32	EEPROM error: Configuration	E RD (read error) E WR (write error)	
d35	EEPROM error: Calibration		
d36	EEPROM error: Potentiometer calibration		
d41	EEPROM error: Serial number		
d42	EEPROM error: Manufacturing parameters		
d43	EEPROM error: Transit time		
d44	EEPROM error: Status messages		
d45	EEPROM error: Statistics		
Test - Actions			
d51	Start zero calibration	ZER	⇒ Start-up and configuration
d52	Start initialization	INI	
d53	Perform reset	RES	
d54	Load default settings in actuator	DEF	
d55	Testing display	TEST (all segments displayed)	
Test - Transit time			
d61	Start transit time measurement	RUN	⇒ Start-up and configuration
d62	Measured transit time	Read only in s	
d63	Measured travel	Read only in mm	
d00	Exit level	>ESC	-



Other parameters of the service level can viewed in the TROVIS-VIEW software.

16.14.5 Communication level

Code	Parameters	Display/selection ¹⁾	Default
Serial interface			
A51	Communication	ENAB (enabled) DISA (disabled)	ENAB
Interface module			
A61	Communication	ENAB (enabled) DISA (disabled)	ENAB
A62	Interface module	485 (RS-485) USB (USB) ETH (Ethernet) NONE (without)	NONE
A63	Protocol	AUTO (automatic: SSP, Modbus) MODX (Modbus, adjustable)	AUTO
Modbus interface module			
A64	Station address	1 to 247	1
A65	Baud rate (in Baud)	1200 2400 4800 9600 192 (19200)	9600
A66	Stop bits and parity	1SNP (1 stop bit, no parity) 1SEP (1 stop bit, even parity) 1SOP (1 stop bit, odd parity) 2SNP (2 stop bits, no parity)	1SNP
A67	Bus failure monitoring in min (timeout)	0 to 99	0
A00	Exit level	>ESC	

¹⁾ Select ESC to cancel

16.14.6 Characteristic level

Code	Parameters	Selection	Default	Chapter	Customer-specific data
H0	X0	0.0 to 100.0 %	0.0 %	⇒ Start-up and configuration	
Y0	Y0	0.0 to 100.0 %	0.0 %		
H1	X1	0.0 to 100.0 %	10.0 %		
Y1	Y1	0.0 to 100.0 %	10.0 %		
H2	X2	0.0 to 100.0 %	20.0 %		
Y2	Y2	0.0 to 100.0 %	20.0 %		
H3	X3	0.0 to 100.0 %	30.0 %		
Y3	Y3	0.0 to 100.0 %	30.0 %		
H4	X4	0.0 to 100.0 %	40.0 %		
Y4	Y4	0.0 to 100.0 %	40.0 %		
H5	X5	0.0 to 100.0 %	50.0 %		
Y5	Y5	0.0 to 100.0 %	50.0 %		
H6	X6	0.0 to 100.0 %	60.0 %		
Y6	Y6	0.0 to 100.0 %	60.0 %		
H7	X7	0.0 to 100.0 %	70.0 %		
Y7	Y7	0.0 to 100.0 %	70.0 %		
H8	X8	0.0 to 100.0 %	80.0 %		
Y8	Y8	0.0 to 100.0 %	80.0 %		
H9	X9	0.0 to 100.0 %	90.0 %		
Y9	Y9	0.0 to 100.0 %	90.0 %		
H10	X10	0.0 to 100.0 %	100.0 %		
Y10	Y10	0.0 to 100.0 %	100.0 %		
H00	Exit level				

16.15 Further codes on the display

Code	Function	Status	Text
F11	Zero calibration	Active	ZERO
F12	Initialization	Active	INIT
F13	Transit time measurement	Active	RUN
F41	Blocking protection	Active	BPRO
F42	Blockage removal	Active	BREM
F61	Retract actuator stem in manual level	Active	MIN
F63	Extend actuator stem in manual level	Active	MOUT
F64	Stop actuator stem in manual level	Active	MSTO

16.16 Excerpt from Modbus list

The electric actuator in firmware version 3.10 and higher can be fitted with an RS-485 module to use the Modbus RTU protocol. This protocol is a master/slave protocol. In this case, a control station is the master and the electric actuator the slave, for example.

The following Modbus functions are supported:

Code	Modbus function	Application
1	Read Coils	Read state of several digital outputs in bit format
3	Read Holding Registers	Read several parameters
5	Write Single Coil	Write a single digital output in bit format
6	Write Single Register	Write a value into a single holding register
15	Write Multiple Coils	Write several digital outputs in bit format
16	Write Multiple Registers	Write a value into several holding registers

The electric actuator can issue the following Modbus error responses:

Error code	Malfunction	Cause
1	Illegal function	The function code is not supported.
2	Illegal data address	A register address is invalid or write-protected.
3	Illegal data value	A value contained in the data is not allowed or not plausible.
4	Slave device failure	An unrecoverable error occurred during an action.
6	Slave device busy	The slave is busy and cannot accept the query.

Several important data points from the Modbus data point list are listed below. The entire data point list is available on request.

i Note

Data are saved in a non-volatile EEPROM. This type of memory has a limited life of at least 100,000 write operations per memory address. It is almost impossible to exceed the maximum number of write operations if configurations and data are only changed manually using TROVIS-VIEW or at the device.

If parameters are changed automatically (e.g. by Modbus communication), make sure to observe the maximum number of write operations and take appropriate action to prevent that parameters are written too frequently.

HR	Designation	Access	Transmission range		Display range	
			Start	End	Start	End
Actuator version						
1	Device type (3374 or 3375)	R	3374	3375	3374	3375
2	Reserved					
3	Revision	R	300	9999	3.00	99.99
4	Part one of serial number (top four digits)	R	0	9999	0	9999
5	Part two of serial number (bottom four digits)	R	0	9999	0	9999
6	Firmware version	R	100	9999	1.00	99.99
7	Released firmware version	R	0	1	0	1
8	Modbus station address	R	0	255	0	255

Appendix A (configuration instructions)

HR	Designation	Access	Transmission range		Display range	
			Start	End	Start	End
9	Gear version	R	0	2	0	2
Control						
10	Application	R	0	4	0	4
11	Direction of action	R	0	1	0	1
Inputs (operating values) for positioner application						
12	Positioning value in %	R/W	0	1000	0	100.0
13	Input signal in mA or V	R	0	2400	0	24.0
14	Unit of input signal	R	0	1	0	1
Inputs (operating values) for PID controller application						
15	Process variable in unit (PID controller)	R	-10000	10000	-1000	1000
16	Set point in unit (PID controller)	R	-10000	10000	-1000	1000
17	Unit (PID controller)	R	0	3	0	3
Operating values (outputs)						
18	Travel in %	R	0	1000	0	100.0
19	Travel in mm	R	0	1000	0	100
20	Set point deviation of positioner in % (positioning value/travel)	R	-1000	1000	0	100
21	Set point deviation of PID controller in % (set point/process variable)	R	-1000	1000	0	100
Operating values (position feedback)						
22	Position feedback in %	R	0	1000	0	100.0
23	Position feedback in mA/V	R	0	240	0	24.0
24	Unit of position feedback	R	0	1	0	1
Manual level of control station						
25	Manual positioning value in manual level of control station in %	R/W	0	1000	0	100.0
26	Set point deviation of manual level (control station) in %	R	-1000	1000	-100	100.0
Process data						
27	Positioning value (manual level on site) in %	R	0	1000	0	100.0
28	Status of positioning value	R				

Binary operating data

CL	Designation COILS (1-bit)	Access	Status 0	Status 1
Operating states				
1	Error during operation	R	No	Yes
2	Maintenance demanded	R	No	Yes
3	Manual level on site active	R	No	Yes

CL	Designation COILS (1-bit)	Access	Status 0	Status 1
4	Enable manual level of control station (travel adjustment)	R/W *H	No	Yes
Binary input				
5	Binary input status	R	OFF	ON
6	Binary input (switching contact)	R	OFF	ON
Limits				
7	State of electronic limit contact 1	R	OFF	ON
8	State of electronic limit contact 2	R	OFF	ON
9	Electronic limit contacts exist	R	OFF	ON
Limit contact				
10	Torque switch: Actuator stem retracted	R	OFF	ON
11	Torque switch: Actuator stem extended	R	OFF	ON
Binary output				
12	Logical state of binary output	R	OFF	ON
13	Binary output (switching contact)	R	OFF	ON
14	Enable manual level of control station (binary output)	R/W	No	Yes
15	Logical state of binary output (manual level of control station)	R/W	OFF	ON
Fatal errors				
16	Final test failed	R	No	Yes
17	Plausibility error	R	No	Yes
18	Motor or potentiometer not turning	R	No	Yes
19	Both limit contacts are active	R	No	Yes
20	Retracting of actuator stem canceled	R	No	Yes
21	Extending of actuator stem canceled	R	No	Yes
22	Blockage	R	No	Yes
23	Input signal failure	R	No	Yes
24	Sensor failure	R	No	Yes
EEPROM error				
25	Basic setting: state	R	No	Yes
26	Basic setting: cause	R	Read error	Write error
27	Settings: state	R	No	Yes
28	Settings: cause	R	Read error	Write error
29	Calibration: state	R	No	Yes
30	Calibration: cause	R	Read error	Write error
31	Potentiometer calibration: state	R	No	Yes
32	Potentiometer calibration: cause	R	Read error	Write error
33	Serial number: state	R	No	Yes
34	Serial number: cause	R	Read error	Write error
35	Manufacturing parameter: state	R	No	Yes
36	Manufacturing parameter: cause	R	Read error	Write error
37	Transit time: state	R	No	Yes
38	Transit time: cause	R	Read error	Write error
39	Status messages: state	R	No	Yes



Appendix A (configuration instructions)

CL	Designation COILS (1-bit)	Access	Status 0	Status 1
40	Status messages: cause	R	Read error	Write error
41	Statistics: state	R	No	Yes
42	Statistics: cause	R	Read error	Write error
Functions				
43	Zero calibration active	R	No	Yes
44	Initialization in progress	R	No	Yes
45	Blocking protection active	R	No	Yes
46	Blockage removal active	R	No	Yes
States				
48	Active controller (only application: temperature closed-loop control upon input signal failure)	R	No	Yes
49	Excessive temperature inside the actuator	R	No	Yes
50	Priority position active	R	No	Yes
51	No initialization performed	R	No	Yes

17 Appendix B

17.1 Parts for retrofitting and accessories

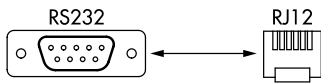
Table 21: Parts for retrofitting and accessories

Parts for retrofitting/accessories	Order no.
Set with three cable glands M20x1.5 with metal nut (A/F 23/24; spare part)	1400-8828
Mounting kit V2001	1400-9515
Spacer to mount the actuator on Type 3323 Valve	0340-3031
Yoke to mount the actuator on Type 3260 Valve (DN 65 to 80)	1890-8696
Yoke to mount the actuator on Type 3260 Valve (DN 100 to 150)	1400-8822
Mechanical limit contacts	100213441
Electronic limit contacts	1402-0591
RS-485 module	1402-1522
Hardware package consisting of: <ul style="list-style-type: none"> - Memory pen-64 - Connecting cable RJ-12/D-sub, 9 pin - Modular adapter 	1400-9998
Memory pen-64	1400-9753 
Connecting cable RJ-12/D-sub, 9 pin	1400-7699 
Modular adapter	1400-7698 
USB to RS-232 adapter	8812-2001 
TROVIS-VIEW software (free of charge)	► www.samsongroup.com > DOWNLOADS > Software & Drivers > TROVIS-VIEW

17.2 After-sales service

Contact our after-sales service for support concerning service or repair work or when malfunctions or defects arise.

You can reach our after-sales service at the following e-mail address:

▶ aftersaleservice@samsongroup.com

The addresses of SAMSON AG, its subsidiaries, representatives and service facilities worldwide can be found on our website (▶ www.samsongroup.com) or in all product catalogs.

Please submit the following details:

- Type designation
- Material number
- Serial number
- Firmware version

Service key number	1732
Customized key number	



SAMSON AKTIENGESELLSCHAFT
Weismüllerstraße 3 · 60314 Frankfurt am Main, Germany
Phone: +49 69 4009-0 · Fax: +49 69 4009-1507
samson@samsongroup.com · www.samsongroup.com